

SAARLAND – MOSEL – HUNSRÜCK

ADAC RALLYE DEUTSCHLAND

SUPPLEMENTARY REGULATIONS



ADAC

Alle Infos unter: adac.de/rallye-deutschland

Die Partner der ADAC Rallye Deutschland:

Table of Contents

1. INTRODUCTION	
1.1 Announcement	
1.2 Road Surface	
1.3 Overall SS distance and total distance of the itinerary	
2. ORGANISATION	
2.1 FIA titles for which the rally counts	
2.2 Visa numbers – FIA and ASN	
2.3 Organiser's name, address and contact details	
2.4 Organising committee	
2.5 Stewards	
2.6 FIA Delegates	
2.7 Senior officials	
2.8 HQ location and contact details	
2.9 Official Notice Board	
2.10 Locations of parc fermé	
3. PROGRAMME	
3.1 Programme before the rally week	
3.2 Programme during the rally week	
4. ENTRIES	
4.1 Closing date for entries	
4.2 Entry procedure	
4.3 Number of competitors accepted and classes	
4.4 Entry fees / entry packages	
4.5 Payment details	
4.6 Refunds	
5. INSURANCE/LIMITATION OF LIABILITY/ COSTS MEDICAL CARE/AMENDEMENTS	
6. ADVERTISING AND IDENTIFICATION	
6.1 Organisers' obligatory advertising	
6.2 Optional advertising	
6.3 Identification numbers	
6.4 Restrictions on advertising	
7. TYRES	
7.1 Tyres specified for use during the rally	
7.2 Tyres quantities for use during the rally	
8. FUEL	
8.1 Ordering procedure	
8.2 Closing date for ordering FIA fuel	
8.3 Dispensing method for non-priority drivers	
8.4 Technical requirements	
9. RECONNAISSANCE	
9.1 Procedure for registration	
9.2 Specific and/or national restrictions – speed limit on special stages	
9.3 Installation of speed control checking devices	
9.4 Inspection of the Special Stages Panzerplatte and of non-public roads	
10. ADMINISTRATIVE CHECKS	
10.1 <u>Original</u> documents to be presented	
10.2 Timetable	
11. SCRUTINEERING, SEALING AND MARKING	
11.1 Scrutineering venue and timetable	
11.2 Mud Flaps (Appendix J Article 252.7.7)	
11.3 Windows/Nets (Appendix J Article 253.11)	
11.4 Driver's safety equipment	
11.5 Sound level	
11.6 Special requirements	
11.7 Installation of FIA Safety tracking device	
11.8 Tyre Marking	
12. OTHER PROCEDURES	
12.1 Shakedown	
12.2 Ceremonial start procedure and order	
12.3 Start of the rallye	
12.4 Finish procedure	
12.5 Any special procedures / activities including the organisers' promotional activities	
12.6 Start Order and Starting Intervals	
12.7 Official time used during the rally	
12.8 Flexi Service	
12.9 Permitted early check in	
12.10 Service Park	
12.11 Route Note Cars	
12.12 Regrouping St. Wendel (Saturday)	
12.13 Power Stage	
13. IDENTIFICATION OF OFFICIALS	
14. PRIZES	
15. FINAL CHECKS AND PROTESTS	
15.1 Final Checks	
15.2 Protest fees	
15.3 Appeal fees	
Appendices:	
1. Itinerary (V3)	
2. Reconnaissance Schedule (V2)	
3. Competitors Relations Officers	
4. Door Plates, Competition Numbers and Drivers' Names	
5. Reminders FIA Appendix L	
6. SAS Tracker Competitor User Manual	
7. Tracker Fitting Kit Instructions	
8. Start Light Sequence	

1. INTRODUCTION

1.1 Announcement

This rally will be run in compliance with the International Sporting Code and its appendices, the 2019 FIA World Rally Championship Sporting Regulations, the National Sporting Regulations which comply with the FIA regulations and these Supplementary Regulations.

Modifications, amendments and/ or changes to these Supplementary Regulations will be announced only by numbered and dated bulletins (issued by the organiser or the Stewards).

Additional information will be published in Rally Guide 2, issued on 22 July 2019. The 2019 FIA World Rally Championship Sporting Regulations can be found at: www.fia.com

Should any dispute arise as to the interpretation of the present Regulations, only the English version will be used.

1.2 Road Surface

Tarmac.

1.3 Overall SS distance and total distance of the itinerary

Overall SS distance: 344,04 km

Total distance: 1.228,26 km

2. ORGANISATION

2.1 FIA titles for which the rally counts

FIA World Rally Championship for Drivers
FIA World Rally Championship for Co-drivers
FIA World Rally Championship for Manufacturers
FIA WRC 2 PRO Championship for Drivers
FIA WRC 2 PRO Championship for Co-drivers
FIA WRC 2 PRO Championship for Manufacturers
FIA WRC 2 Championship for Drivers
FIA WRC 2 Championship for Co-Drivers
FIA RGT Cup for Drivers
FIA RGT Cup for Co-Drivers

2.2 Visa numbers – FIA and ASN

FIA visa: **10WRC/280619** issued on: 28.06.2019

ASN visa: **181/19** issued on: 28.06.2019

2.3 Organiser's name, address and contact details

Organiser's name: ADAC e.V., Hansastraße 19, D-80686 München

Sporting management: ADAC Saarland SFW GmbH, Untertürkheimer Str. 39-41, 66117 D-Saarbrücken

Address and Contact Details:

ADAC Rallyebüro, Untertürkheimer Str. 39-41, D-66117 Saarbrücken, Fax: +49 681 927447-10

Tanja Geilhausen	Tel.: +49 681 927447-15	tanja.geilhausen@rallye-deutschland.de
Berthold Hantel	Tel.: +49 681 927447-13	berthold.hantel@rallye-deutschland.de
Günter Jung	Tel.: +49 681 927447-11	guenter.jung@rallye-deutschland.de
Detlef Thul	Tel.: +49 681 927447-12	detlef.thul@rallye-deutschland.de
Thomas Winkler	Tel.: +49 681 927447-14	thomas.winkler@rallye-deutschland.de

Internet: www.adac.de/rallye-deutschland

2.4 Organising committee

Hermann TOMCZYK, Friedhelm KISSEL, Nobert HEINZ, Stefan BAYER, Thomas KRISAM, Kai HANTEL, Jutta KLEINSCHMIDT, Thomas VOSS, Günter JUNG, Andreas BACHMEIER, Timo LEWERENZ

2.5 Stewards

Mr. Timo RAUTIAINEN (FIN) (Chairman), Mr. Adrian STAFFORD (AUS), Mr. Wolfgang GASTORFER
Secretary of the Stewards: Ms. Yvonne GILLI

2.6 FIA Delegates

Sporting Delegate: Mr. Andrew WHEATLEY
Safety Delegate: Ms. Michèle MOUTON
Medical Delegate: Dr. Cem BONEVAL
Technical Delegate: Mr. Jérôme TOQUET
Assistants to Technical Delegate: Mr. Karmo UUSMAA
Mr. Clement CLERC
Mr. Emanuele SAGLIA
Mr. Lionel BERARD
Media Delegate: Mrs. Vera DUSSAUSAYE

2.7 Senior officials

Clerk of the Course: Friedhelm KISSEL
Deputy Clerks of the Course: Stefan BAYER, Thomas KRISAM, Kai HANTEL
Assistant Clerks of the Course: Tanja GEILHAUSEN (Rally Control),
Matthias HEINZ (Rally Control)
Chief Safety Officer: Kai HANTEL
Deputy Chief Safety Officers: Berthold HANTEL, Hans-Peter BAEHR, Wolfgang HUHMANN, Volker PAUL
Event Manager Günter JUNG
Secretary of the Event: Tanja GEILHAUSEN
Permanent Rally Secretariat: Tanja GEILHAUSEN, Berthold HANTEL, Günter JUNG, Detlef THUL,
Thomas WINKLER
Spectator Management: Ralph LEISTENSCHNEIDER, Detlef THUL
Regional Organisers: Thomas WINKLER (Service Park), Thomas KRISAM (Saarland), Werner
REHLES (Hunsrück), Helmut WEYER (Mosel)
Chief National Scrutineer: Florian MAI
Competitors Relations Officers: Karl Friedrich BECK, Josef KASPAR, Christian RIEDEMANN, Simone
SCHLEIMER
Chief Medical Officer: Dr. Hanns LANG
Assistant Chief Medical Officer: Dr. Dirk JOACHIMSEN
Chief Media Officer: Kay-Oliver LANGENDORFF
Environmental Officers: Dr. Rüdiger BÖNGELER, Christoph SCHACKMANN, Tilman KLUGE,
Helmut ROTZAL, Guide VOGT, Dr. Betina REUTER
Assistants (Service Park): Tobias KNOPP, Carsten ALEXY, Harald RABE
Chief Timing Marshal: Peter ROTHER
Results Co-ordinator: Winfried WEBER

2.8 HQ location and contact details

Seezeit-Lodge, Am Bostalsee 1, 66625 Gonneseiler
Rally HQ Phone: +49 681 927447-15, Fax: +49 681 927447-10

Rally Office Opening Hours:

Monday	19 August 2019	14:00 – 20:00
Tuesday	20 August 2019	08:00 – 21:00
Wednesday	21 August 2019	08:00 – 21:00
Thursday	22 August 2019	08:00 – 22:00
Friday	23 August 2019	08:00 – 22:00
Saturday	24 August 2019	07:00 – 23:00
Sunday	25 August 2019	06:00 – 18:30

2.9 Official Notice Board

Foyer of Rally Headquarters Hotel Seezeit-Lodge, Gonneseiler. All publications will – for information only (no official character) – also be posted on the organiser’s website www.adac.de/rallye-deutschland.

2.10 Locations of parc fermé

Service park Bostalsee:
- All days

3. PROGRAMME

3.1 PROGRAMME BEFORE THE RALLY WEEK

Wednesday, 19 June 2019	
Supplementary Regulations published (at latest)	www.adac.de/rallye-deutschland
Friday, 28 June 2019	
Closing date for submission of radio licence applications (late applications may be refused!) to Bundesnetzagentur Mainz	ShortTerm@BNetzA.de
Saturday, 6 July 2019, 18:00 hrs	
Closing date for entries for non-priority drivers for reduced entry fee	Rally Office
Monday, 22 July 2019	
Publication of Rally Guide 2	Rally Office
Tuesday, 23 July 2019	
Closing date for entries	Rally Office
Closing date for order of extra facilities and space in service park	Rally Office
Closing date for order of extra material	Rally Office
Road-Books and rally maps available	Rally Office
Wednesday, 24 July 2019	
Closing date for accreditation requests national media	www.adac.de/motorsport
Wednesday, 31 July 2019	
Closing date for accreditation requests international media	FIA
Closing date for requests for consecutive service areas	Rally Office
Closing date for helicopter licence applications	Rally Office

Closing date for all competitors wishing to use FIA fuel to notify their fuel requirements

mehmet.basar@total.com

3.2 PROGRAMME DURING THE RALLY WEEK

From Monday, 19 August 2019, 14:00 and during Rally HQ opening times		
	Collection of material and documents. FIA WRC registered Manufacturers may send a representative (duly assigned in writing) for the collection of material.	Rally HQ
Monday, 19 August 2019		
14:00-20:00hrs	Registration for reconnaissance Administrative checks and collection of materials	Rally HQ Rally HQ
14:00-20:00hrs	Availability of recce GPS recorders for reconnaissance (all drivers)	Rally HQ
Tuesday, 20 August 2019		
08:00-21:00hrs	Administrative checks and collection of material	Rally HQ
08:00-20:00hrs	Reconnaissance of special stages and shakedown	Recce Schedule
12:00hrs	Registration for Route Note Cars closes (drivers entered with a World Rally car or eligible to score points in the WRC 2 Pro Championship)	Rally HQ
14:00-18:00hrs	Opening hours media accreditation and media centre	Media Centre
16:00-21:00hrs	Availability of FIA Safety tracking device at the SAS Truck in the service park Bostalsee	SAS truck (SP)
Wednesday, 21 August 2019		
08:00-12:00hrs	Administrative checks and collection of material	Rally HQ
08:00-17:00hrs	Reconnaissance of special stages	Recce Schedule
08:00-21:00hrs	Opening hours media accreditation	Media Centre
08:00-21:30hrs	Opening hours media centre	Media Centre
TBA	Sealing of parts and delivery of Scrutineering Certificate for Manufacturers' cars will be published by Bulletin.	SP teams' area
From 15:00hrs	Scrutineering including component sealing for cars of P1 drivers (except Manufacturers), of P2P / P2 / RGT and of non-priority drivers.	Servicepark
16:00hrs	Briefing with the team managers (WRC registered manufacturers), Organizers meeting room	Rally HQ
17:00-19:00hrs	Return of GPS recorders (not for Route Note Car Users)	SP HQ
19:00hrs	Safety briefing for drivers and codrivers (*) for new tracking and timing system and guideline from the supplier SAS (* list of compulsory attendance by CoC Communication)	TBA
Thursday, 22 August 2019		
From 07:00hrs	Scrutineering continues (if necessary)	Servicepark
07:00-18:00hrs	Opening hours media accreditation	Media Centre
07:00-23:00hrs	Opening hours media centre	Media Centre
08:30 hrs	Publication of start list for Shakedown	Rally HQ
10:00-11:30hrs	Shakedown for P1 and P2P drivers	Shakedown
11:30-13:30hrs	Shakedown for P1, P2P, P2 and RGT drivers	Shakedown
13:30-15:30hrs	Shakedown for non-priority drivers	Shakedown

10:00hrs	Latest time to return recce pass	Rally HQ/SP HQ
14:00hrs	Meet the Crews	Service Parc
14:30hrs	FIA pre-event press conference	Media Centre
16:00hrs	Publication of start list for Sections 1 and 2	Rally HQ
18:45hrs	Start Section 1 (1 st car), SP Bostalsee	Service Parc
TBA	Helicopter and drone pilots' briefing	Rally HQ
From 19:38hrs	Finish of Thursday and Parc fermé IN Bostalsee	PF Bostalsee
Friday, 23 August 2019		
05:00hrs	Latest time for all cars that will re-start to return to the Parc fermé	PF Bostalsee
08:00-14:00hrs	Opening hours media accreditation	Media Centre
08:00-00:00hrs	Opening hours media centre	Media Centre
09:00hrs	Re-Start Friday (1 st car), service park Bostalsee	Service Parc
21:30hrs	Publication of start list for Saturday	Rally HQ
23:00hrs	Finish of Friday and last car in Parc Fermé Bostalsee	PF Bostalsee
Saturday, 24 August 2019		
03:25hrs	Latest time for all cars that will re-start to return to the Parc fermé	PF Bostalsee
06:45-01:00hrs	Opening hours media centre	Media Centre
07:25hrs	Re-Start Saturday (1 st car), Parc Fermé Bostalsee	PF Bostalsee
22:30hrs	Publication of start list for Sunday	Rally HQ
Sunday, 25 August 2019		
01:00hrs	Finish of Saturday and last car in Parc Fermé Bostalsee	PF Bostalsee
02:20hrs	Latest time for all cars that will re-start to return to the Parc Fermé	PF Bostalsee
06:00-00:00hrs	Opening hours media centre	Media Centre
06:20hrs	Re-Start Sunday (1 st car), Parc Fermé Bostalsee	PF Bostalsee
13:21hrs	Finish of Sunday (1 st car)	SP Bostalsee
From 14:00hrs	Podium ceremony for all cars	SP Bostalsee
14:45hrs	FIA post-event press conference	Media Centre
After podium	Final scrutineering, location: Scrutineering building, Service park Bostalsee	SP Bostalsee
16:00hrs	Publication of provisional classification	Rally HQ
From 19:00hrs	Closing party for team members and organisation (upon invitation)	TBA

4. ENTRIES

4.1 Closing date for entries

Tuesday, 23 July 2019, 17:00hrs

4.2 Entry procedure

Anyone wishing to take part in ADAC Rallye Deutschland 2019 must use [the FIA registration platform](#). WRC Manufacturers, WRC 2 Pro, WRC2 and RGT competitors who wish to score points shall make their entries by using the standard entry form for their championships available in the FIA application at <https://registrations.fia.com/rally>

Any Competitors entered in the FIA WRC 2 Pro and WRC 2 championships wishing to enter ADAC Rallye Deutschland 2019, but not wishing to collect points for their respective championships, must use the non priority entry form as detailed hereafter.

Any non-priority drivers must register and fill-in the electronic entry form available at <https://registrations.fia.com/wrcger> duly completed before the closing date of entries.

Please note that the FIA registration platform requires a user ID and a password to access the entry system. The FIA will need time to register you in the system and open your user account. Please do not wait until the last moment to make your entry in order not to miss the entry closing date. The user account application is available via a link on the registration page stated above.

The entry will only be accepted if accompanied by the total amount of the entry fee. To be accepted, competitors must send a proof of payment of the entry fee by e-mail to the secretary of the event (tanja.geilhausen@rallye-deutschland.de) by the closing date of entries.

In compliance with Article 3.9 of the 2019 FIA International Sporting Code, foreign competitors/drivers must be in possession of the approval of their own ASN which must be attached to the entry form or produced at administrative checks at the latest. With the submission of the entry form, each foreign competitor and/or driver/co-driver declares that he/she is in possession of this authorisation.

4.3 Number of competitors accepted and classes

The maximum number of competitors will be 90. If more than 90 entries are received the organiser reserves the right to decide which entries among the non-priority drivers/National cars will be accepted.

Classes

With reference to Art. 4 in 2019 FIA WRC Sporting Regulation, the classes will be divided according to the table below.

CLASSES	GROUPS	
RC 1	World Rally Cars: 1.6 T engine	<ul style="list-style-type: none"> - World Rally Cars, complying with the 2019 Appendix J, Art. 255A, when driven by a driver who has obtained the approval of the FIA - World Rally Cars homologated before 31.12.2013, complying with homologation extension 100/01 KSR and its WR extension, and with the 2013 Appendix J, Art. 255A. - World Rally Cars homologated as from 01.01.2014, complying with homologation extension 200/01 WRC and with the 2016 Appendix J, Art. 255A. Only WRC cars with an FIA passport issued before 31/12/2016 are allowed. - World Rally Cars homologated as from 01.01.2015, complying with homologation extension 300/01 WRC and with the 2016 Appendix J, Art. 255A. Only WRC cars with an FIA passport issued before 31/12/2016 are allowed.
RC2	Group R5 (VR5)	<ul style="list-style-type: none"> - Group R5 cars conforming to the 2019 Appendix J, Art. 261.
RGT	RGT cars	<ul style="list-style-type: none"> - Group RGT cars conforming to the 2019 Appendix J, Art. 256.

RC3		R3 (atmo / over 1600 cc and up to 2000cc – VR3C and turbo over 1067cc and up to 1333cc – VR3C)	- Group R cars conforming to the 2019 Appendix J, Art. 260
		R3 (turbo / up to 1620 cc / nominal – VR3T)	- Group R cars conforming to the 2019 Appendix J, Art. 260D.
RC4	RC4A	R2 (atmo / over 1600 cc and up to 2000cc – VR2C and turbo over 1067cc and up to 1333cc – VR2C)	- Group R cars conforming to the 2019 Appendix J, Art. 260
	RC4B	R2 (atmo / over 13900 cc and up to 1600cc – VR2B and turbo over 927cc and up to 1067cc – VR2B)	- Group R cars conforming to the 2019 Appendix J, Art. 260 - Group R cars conforming to the 2018 Appendix J, Art. 260 (VR2B homologated before 31/12/2018)
RC 5		R1 (atmo up to 1600cc – VR1 and turbo up to 1333cc – VR1)	- Group R cars conforming to the 2019 Appendix J, Art. 260
		R1 (atmo up to 1600 cc – VR1 A/VR1B and turbo up to 1067cc – VR1A/VR1B)	- Group R cars conforming to the 2018 Appendix J, Art. 260 (VR1 and VR1B homologated before 31/12/2018)

4.4 Entry fees / entry packages

4.4.1 FIA registered Manufacturers and Support Championship competitors:

According to Appendix VI of the 2019 FIA WRC Sporting Regulations (all these fees are net amounts, legal VAT of currently 19% must be added).

4.4.2 Other teams (all the fees mentioned below are net amounts, legal VAT of currently 19% must be added)

With the organiser's optional advertising and entry before 6 July 2019, 18:00 hrs:

Private German entries	€ 2.000 (+ 19%)
Private foreign entries	€ 3.000 (+ 19%)
Legal entries	€ 6.000 (+ 19%)

Without the organiser's optional advertising and entry before 6 July 2019, 18:00 hrs:

Private German entries	€ 3.500 (+ 19%)
Private foreign entries	€ 5.000 (+ 19%)
Legal entries	€ 8.000 (+ 19%)

With the organiser's optional advertising and entry after 6 July 2019, 18:00 hrs:

Private German entries	€ 2.250 (+ 19%)
Private foreign entries	€ 3.250 (+ 19%)
Legal entries	€ 6.250 (+ 19%)

Without the organiser's optional advertising and entry after 6 July 2019, 18:00 hrs:

Private German entries	€ 3.750 (+ 19%)
Private foreign entries	€ 5.250 (+ 19%)
Legal entries	€ 8.250 (+ 19%)

- Private German entry: The competitor is one of the two crew members or a club competitor (no company/commercial competitor), competitor **and** 1st driver must hold a competitor's/driver's licence issued by the DMSB (Deutscher Motor Sport Bund).

- Private foreign entry: The competitor is one of the two crew members or a club competitor (no company/commercial competitor or third person as competitor), competitor and/or 1st driver holding a competitor's/driver's licence issued by a Sporting Authority affiliated to the FIA, other than the DMSB (Deutscher Motor Sport Bund).
- Company/commercial competitor.

4.4.3 Entry packages

Manufacturers and Support Championship competitors: In compliance with Appendix VI of the 2019 FIA WRC Sporting Regulations.

Other teams:

	Private entries	Company/ commercial competitors
Service park	See point 4.4.5 below	
Car plates		
Guest plate	0	1
Service plate	1	2
Auxiliary plate	0	1
Passes		
Driver passes	2	2
Team passes	4	12
Team guest passes	0	4
Documents		
Road Book sets	1	2
Route maps	2	3
Programme	2	3
Result books	Website	

4.4.4 Additional material

For each additional set of service documents: (maximum of 2 sets in total for each crew; WRC registered Manufacturer and Support Championship registered teams: see FIA WRC Regulations)	200 €
Each set "Auxiliary"	400 €
Each additional set of Road-Books	100 €
Each additional route map	10 €

All additional material should be ordered within the deadline as specified under point 3.
All the amounts under 4.4.4 are inclusive of VAT.

4.4.5 Areas in the service park

4.4.5.1 Manufacturer Teams

- a) Space strictly as the figures given in the Appendix VI of the 2019 FIA WRC Sporting Regulations.
- b) Additional car(s) as per Appendix VI: Depending on available space after allocation pursuant to a) above, on a first-come-first-serve basis.

4.4.5.2 Support Championships (WRC2 PRO / WRC2):

Space strictly in compliance with the 100 m² given in Appendix VI of the 2019 FIA WRC Sporting Regulations.

4.4.5.3 Other competitors:

10x10 m.

4.4.5.4 All competitors

Any competitor requiring more space and/or a different layout than indicated above must submit his/her request together with the entry form or until the entry closing date at the latest.

The organiser will try to satisfy the needs as much as possible and an additional fee of 40€ per m² will become due. After this date requests will not be accepted. The amount under 4.4.5.4 is inclusive of VAT.

4.5 Payment details

All entry fees must be paid by bank transfer to the following bank account:

Bank name: Bayerische Landesbank München
Account holder: ADAC e.V. (**account holder must be mentioned on all bank transfers**)
SWIFT CODE: BYLADEMMXXX
IBAN: DE60 7005 0000 0009 0558 30

Cheques are not accepted. Any bank charges incurred must be paid by the competitors in addition to the entry fee. Please ensure that the competitor's name is included as reference on all bank transfers.

Additional important information regarding entry fee invoices and VAT is included in point 4.2 in Rally Guide 1.

4.6 Refunds

Entry fees will be refunded in full only:

- To candidates whose entry has not been accepted.
- In the case of the rally not taking place.

The organisers may refund part of the entry fee to those competitors who, for reason of "force majeure" (duly certified by their ASN), are unable to start in the rally. This must be applied for in writing giving the reason for claim including bank and account details.

5. INSURANCE / LIMITATION OF LIABILITY / COSTS FOR MEDICAL CARE / AMENDMENTS

Insurance:

The organiser provides a third party liability insurance with the cover of €10 million lump sum for the event for personal injuries, property damage and pecuniary loss.

The insurance will come into effect at the start of the rally and will cease at the end of the rally or at the moment of withdrawal or retirement of the crew. The liability insurance for the road sections between the special stages will nevertheless only be granted subsidiary and exists only for competitors' cars which do not comply with the minimum cover prescribed in the motor vehicle liability insurance regulations for the Federal Republic of Germany.

By submitting their entries, competitors declare that a car owner's liability insurance with a minimum liability insurance cover for the vehicle to be used exists without restriction.

More details are available upon request.

A copy of a corresponding confirmation of the competitors' insurance, the international insurance card ("green card") or the pink border insurance confirmation must be submitted together with the entry form or be produced at administrative checks at latest.

Competitors are reminded that the reconnaissance is **not** covered by the above insurance and competitors must make their own arrangements.

Competitors'/drivers'/co-drivers' statements regarding the limitation of liability / Release from Claims

The participants (competitors/drivers/co-drivers) take part in the event at their own risk. They bear the responsibility under civil and criminal law for any damage caused by them. With their entries, they waive any claims or rights to pursue action for damages in connection with the event (tests/ reconnaissance of the special stages, shakedown, special stages to perform top speeds or shortest driving times, road sections) against:

- the other participants, the drivers and co-drivers of the course cars as well as their assistants, the owner and proprietors of the other cars,
- the own competitor/ the own drivers/ co-drivers (barring any other special agreements between those) and their own assistants,
- the FIA, the DMSB, the DMSB member organisations, the Deutsche Motor Sport Wirtschaftsdienst GmbH as well as their presidents, executive bodies, managing directors, secretaries general, members and full-time employees and volunteers of these organisations,
- the ADAC e.V., the ADAC SE and against the other companies affiliated or associated with the ADAC e.V. and / or ADAC SE, the ADAC Saarland SFW GmbH, the ADAC Saarland e.V. as well as all other ADAC local and regional clubs, the promoter/series organiser as well as the presidents, executive bodies, directors, managing directors, secretaries general, members and full-time employees as well as volunteers of these organisations,
- the Organiser, the Officials and Delegates, the road owners, the government agencies, the racing services and all other persons involved with the organisation of the event,
- the organisation responsible for the construction and maintenance of roads,
- the agents or other persons employed to perform an obligation on behalf of the above persons and entities.

The liability waiver does not apply for damages or harm to life, body or health or any other damage resulting from the deliberate or gross negligent breach of duty by the group of persons released from liability, nor for damages resulting from the infringement of a contractual obligation committed by the group of persons released from liability. In the case of damages resulting from a slight negligent breach of duty of a contractual obligation, the liability for property damage and pecuniary loss is restricted to the typical foreseeable damage as regards the amounts.

The exclusion from liability shall become effective for all parties concerned upon submission of the entry form to the ADAC or to the Organiser.

The waiver of liability applies to claims for any legal reason whatsoever, including but not limited to claims for damages based on contractual and non-contractual liability and to claims from tortious liability.

Implied exclusions from liability shall remain unaffected.

By submitting their entry, the competitors/ registered owner(s)/ drivers/ co-drivers acknowledge that motor vehicle insurance (motor vehicle third-party liability, Casco comprehensive/collision damage coverage) does not cover any damage or claims incurred during special stages or the shakedown. They undertake to pass this information on to the owner of the vehicle used.

If the participants are not themselves owner of the competition car, they must make sure that the limitation of liability which is part of the entry form is signed by the car owner before the event.

In the case that, notwithstanding this obligation, the above mentioned declaration was not signed by the car owner, the participants discharge all the above mentioned persons from any claim by the car owner.

With regard to claims against the other participants (competitor, driver and co-driver), their assistants, the owners and proprietors of the other cars, the own competitor, drivers, co-drivers and own assistants, this release refers to damages arising in connection with the special stage(s) on which the top speeds or the shortest driving time should be achieved and/or the associated test(s)/reconnaissance. With regard to claims against other persons or bodies, this release refers to damages arising in connection with the event as a whole.

Costs for medical care

Competitors/drivers/co-drivers acknowledge, that full costs in connection with medical care (e.g. first aid treatment and transportation) go to the expense of the patient. It is recommended to take out a policy which covers the costs if it is necessary.

Responsibility, amendments of the regulations, cancellation of the event

The organiser reserves the right to modify the present regulations if considered necessary for reasons of force majeure, safety or upon instruction of the authorities or to cancel the event or single special stages in case that extraordinary circumstances should arise, without assuming any obligations for indemnification, intention and gross negligence excluded. Any modifications will be published by official Bulletin.

6. ADVERTISING AND IDENTIFICATION

6.1 Organisers' obligatory advertising

"ADAC"

6.2 Optional advertising

Eventual optional advertising will be published in a Bulletin, if applicable.

6.3 Identification Numbers

Rally plates and competition numbers will be provided by the Organisers, in accordance with Article 18 of the 2019 FIA WRC Sporting Regulations and as detailed in the Appendix 4.

Service and support vehicle car plates must be placed on the top right corner on the inside of the windscreen.

6.4 Restrictions on advertising

No political, religious, social or abusive advertising. Advertising for private betting and gambling offerers without permission for Germany is prohibited.

Publicity on tobacco is forbidden. This is a restriction self-imposed by the German tobacco industry.

7. TYRES

7.1 Tyres specified for use during the rally

The FIA nominated tyre companies to supply the single tyres in the FIA World Rally Championship 2019 are Michelin and Pirelli. The contacts are given in point 61.1.1 of the 2019 FIA WRC Sporting Regulations.

All the requirements around the use of FIA specified tyres supplied by the nominated tyre companies are detailed in the 2019 FIA WRC Sporting Regulations.

In addition to complying with Articles 60, 61 & 62 of the 2019 FIA WRC Sporting Regulations, the following quantities are confirmed for use.

FIA Nominated Tyre Manufacturer	Tyres List 1 FIA WRC, Art. 60.3.1	Tyres List 2 FIA WRC, Art. 60.2.1	Compound
Michelin	<u>20/65 18 Pilot Sport RH3</u>	<u>20/65 18 Pilot Sport H5</u>	Hard
	<u>20/65 18 Pilot Sport RS</u>	<u>20/65 18 Pilot Sport S6</u>	Soft
	<u>18/65-18 Pilot Sport FW3</u>	<u>18/65-18 Pilot Sport FW3</u>	Wet
Pirelli	<u>235/40-18 Pirelli P Zero RA5</u>	<u>N/A</u>	Hard
	<u>235 / 40-18 Pirelli P Zero RA7+</u>	<u>N/A</u>	Soft
	<u>235/40-18 Pirelli Cinturato RWA</u>	<u>N/A</u>	Wet

- **All competitors entered with a WRC car** List 2 (see FIA-WRC Art 60.2)
- **All P2P & P2 drivers**
All drivers entered with an R5 car who have been entered as P2P or P2 drivers during the current year
Any other drivers entered with an R5 car and designated by the FIA
List 1 (see FIA-WRC Art. 60.3)
- **Non-Priority drivers entered with an R5 car and who have not been entered as P2P or P2 drivers during the current year**
Non priority drivers entered with a 2WD car
(see FIA-WRC Art. 60.4)
- **Priority drivers entered with a 2WD car** (see FIA-WRC Art. 60.5)
- **Drivers entered with RGT cars**
(see FIA-WRC Art. 60.6)

7.2 Tyres quantities for use during the rally

	List 2 tyres (FIA WRC Art 60.2.1) WRC cars only	List 1 tyres (FIA WRC Art. 60.3.1) P2P and P2 drivers Non-Priority drivers of R5 designated by the FIA	All other competitors
Hard	32	30	Free
Soft	26	24	Free
Wet	12	12	Free
Maximum Allocated / No participation to shakedown	32	30	30
Extra if Shakedown carried out	4	4	4
Maximum Allocated / Only in case of participation to Shakedown	36	34	34

Special attention is also drawn to the Appendix V of the 2019 FIA WRC Sporting Regulations regarding tyre regulations!

8. FUEL

All FIA Priority drivers must use the FIA fuel as provided by the FIA appointed supplier which is TOTAL Additifs et Carburants Speciaux who will also carry out fuel ordering, supply and refuel services. The cost of the FIA fuel including refuel services is **€ 5.60 (+ VAT)** per litre, dispensed into rally cars. For further information, see Articles 58 and 59 of the 2019 FIA WRC Sporting Regulations.

8.1 Ordering procedure

All competitors using FIA fuel must place their fuel order directly with TOTAL Additifs et Carburants Speciaux by e-mail to **mehmet.basar@total.com**. The order form issued by TOTAL Additifs et Carburants Speciaux including payment details by bank transfer is available on the event website: www.adac.de/rallye-deutschland.

It is a condition of supply that payment must be received in full before delivery can be made. The balance of non-used fuel will be credited after the rally.

8.2 Closing date for ordering FIA fuel

See point 3 of these Supplementary Regulations.

8.3 Dispensing method for non-priority drivers

RGT- and Non Priority drivers may use either FIA fuel following the same conditions and rules as the Priority drivers, or commercially available pump fuel, dispensed only from pumps at filling stations marked in the Road Book. Should a particular car not be able to cover the distance between two corresponding filling stations due to the individual fuel consumption and the individual fuel tank capacity, FIA fuel may be ordered and refuelled at the FIA refuel zones (deadlines for ordering must be respected!!).

8.4 Technical requirements

According to article 59.3.2 of the 2019 FIA WRC Sporting Regulations, all competitors are required to fit FIA specified refuel couplings. Cars of priority drivers and RGT drivers specifically must be fitted with FIA fuel sample couplings (Art. 59.3.5). Cars equipped solely with FIA specified refuel couplings and using fuel as per Art. 59.1.2 must transport the adaptor in the car and show it at pre-event scrutineering (Art. 59.3.7).

9. RECONNAISSANCE

9.1 Procedure for registration

Prior to reconnaissance, all crews must complete a registration form and collect a reconnaissance pass and a recce vehicle identification at the Rally Headquarters Bostalsee (see Article 3.2). The material will be given to the drivers personally or to a representative duly certified in writing at the Rally Secretariat.

The recce pass form issued by the organiser must be returned at the Rally Headquarters Bostalsee or at the service park Headquarters Bostalsee until **Thursday, 22 August 2019, 10:00hrs**, at the latest. The identification number panels (small format) must be affixed to the upper side of the windscreen and of the rear window, in the centre. The fluorescent orange numbers issued must be placed at the top of both rear side windows. All identifications must be kept visible for the whole duration of the recce period.

9.2 Specific and/or national restrictions – speed limit on special stages

9.2.1 Direction

Each crew may drive the special stages only in **the same direction as the rally**, unless permitted to drive in the opposite direction for very short sections if published in a Communication by the Clerk of the Course. The crews must always enter and leave the special stages through the start and stop controls.

9.2.2 Respect of traffic laws and driving behaviour

All Road Traffic Laws must be strictly observed and the safety and rights of other road users must be respected during reconnaissance. All crews must drive in a manner that does not endanger or inconvenience other traffic or people living near the stages. Competitors must bear in mind that the special stages are not yet closed to public or residential traffic during recce.

9.2.3 Number of persons on board

During each passage through a special stage, a maximum of 2 persons are permitted in the car.

9.2.4 Maximum speed

At all times the maximum speed on special stages will be 90 km/h unless a lower limit is indicated by traffic signs, by signs placed by the organiser or in the Road Books.

9.2.5 Reconnaissance pass

Crews must stop at the start and at the stop of each special stage where a rally official will endorse the crews' reconnaissance pass and at any other location where instructed.

9.2.6 Reconnaissance vehicles

All cars used for reconnaissance must comply with the prescriptions of Article 25.1 of the 2019 FIA WRC Sporting Regulations.

9.2.7 Service during reconnaissance

In compliance with Article 25.4.6 of the 2019 WRC Sporting Regulations.

9.2.8 Participation in reconnaissance only

Any driver wishing to take part in reconnaissance only (see also Art. 25.5 of the 2019 WRC Sporting Regulations) must complete an application form which is available from the organiser and pay a fee of 1.000 € (VAT to be added) for taking part in this reconnaissance. The form has to be returned until the entry closing date.

9.3 Installation of speed control checking devices

In accordance with Article 25.4.4 of the 2018 FIA WRC Sporting Regulations, all cars must carry recce GPS recorders on board during reconnaissance. Location and times for collection and return are specified in Art.3.2. Rental costs:

FIA P1, P2 PRO & P2	300€ + VAT
RGT & non-priority drivers:	130€ + VAT

9.4 Inspection of the Special Stages Panzerplatte and of non-public roads

The special stages "Arena Panzerplatte" and "Panzerplatte" are taking place on a military area and can only be visited with a special access authorisation. Furthermore, also on the other stages there are sections on non-public roads. The competitors get their access authorisation at the recce registration in form of the recce identification number. Beyond that the organiser will not issue any additional access authorisations except for the registered WRC and P2 PRO manufacturers and the tyre manufacturers. They will get one access authorisation per WRC registered manufacturer / P2 PRO registered manufacturer / per tyre manufacturer.

10. ADMINISTRATIVE CHECKS

10.1 Original documents which must be presented:

- Competitor's international licence,
- Driver's and co-driver's international competition licences,
- Driver's and co-driver's valid driving licences,
- Driver's and co-driver's passport or identification,
- ASN authorisation for all foreign competitors, drivers and co-drivers,
- Completion of all details on the entry form,
- Rally car insurance cover certificate (see Article 5 in the present Regulations),
- Rally car registration papers.

After completion of administrative checks, competitors will receive a signed Administrative Clearance Form which must be submitted at scrutineering.

10.2 Timetable

See point 3.2 in these Regulations.

11. SCRUTINEERING, SEALING AND MARKING

11.1 Scrutineering venue and timetable

See point 3.2 of these Regulations. A detailed timetable will be published in a Bulletin. The layout of the scrutineering area will be published in Rally Guide 2.

For scrutineering, all cars must have their sump guards removed for sealing of gearboxes and differentials, and be kept with the car for the purpose of weighing. The homologation form of the rally car and certificates for the roll cage and fuel tank must be brought to scrutineering. Competitors with cars registered in Germany have to present the valid KFP at Scrutineering.

The bodyshell and engine will be marked and to facilitate this, each competitor must prepare their car (engine block) in order to fit a wire, a plate and a seal somewhere on the engine block (on a visible place when the front bonnet is opened).

11.2 Mud Flaps (Appendix J Article 252.7.7)

Mud flaps to prevent splashing towards the front in conformity with Article 252.7.7 of the Appendix J to the 2019 FIA International Sporting Code are authorised.

11.3 Windows/Nets (Appendix J Article 253.11)

The use of silvered or tinted films is not authorized.

11.4 Driver's safety equipment

All items of clothing including helmets and FHR (Front Head Restraint) intended to be used must be produced at scrutineering. Compliance with Appendix L Chapter III will be checked (see Appendix 5 of these regulations).

11.5 Sound level

In accordance with Article 252.3.6 of the Appendix J to the 2019 FIA International Sporting Code.

11.6 Specific requirements

Each competing car must be equipped with a reflective triangle and two fluorescent jackets.

Two belt cutters must be carried on board at all times. They must be easily accessible to the driver and co-driver when seated with their harnesses fastened (Art. 253.6.1.3 Appendix J).

11.7 Installation of FIA Safety tracking device

In accordance with article 40.2.1 of 2019 FIA WRC Sporting Regulations all competitors must make provisions in their rally cars for the installation of the FIA Safety tracking device that comprises an SOS/OK display.

Collection times for the FIA Safety tracking device are given in point 3.2 of these Regulations. A €1200 fully refundable credit card deposit will be collected by STATUS AWARENESS SYSTEM (SAS) from each competitor for the FIA Safety tracking device boxes for the event of loss / damage.

The system must be fitted and connected in all competitors' cars before arrival at scrutineering where they will be checked. Installation instructions are published in Appendix 6 of these regulations.

The FIA Safety Emergency Console System must be removed in the Final Parc Fermé. They must be returned at the same location where they were distributed no later than 17.00hrs on Sunday, 25 August 2019. In the case of final retirement, all the tracking equipment must be returned to SAS at the Service Park as soon as possible after retirement.

11.8 Tyre Marking

The tyre marking zone for Section 1 is located after TC 0.

12. OTHER PROCEDURES

12.1 Shakedown

All P1 and P2P drivers will be required to complete their first passage of Shakedown in the order of Championship classification, and at an interval as determined by the Organiser in consultation with FIA and WRC Promoter.

A start list for this first passage will be published at 08:30h on Thursday 22 August 2019. At the conclusion of these fixed passages, P1 and P2P drivers will be able to continue their shakedown runs.

There will be a technical zone before the shakedown start control and P1 and P2P drivers will be required to be available at the start 10 minutes before their scheduled start time.

12.2 Ceremonial start procedure and order

There will be no ceremonial start. There will, however, be a presentation of the drivers and an autograph session on Thursday, 22nd August 2019. More details will be published in a bulletin.

All rally cars must be brought into the holding area Bostalsee (technical zone/regrouping area) under the following conditions:

- The cars may be brought by a competitor's representative.
- Each car must enter the holding area on Thursday, 22 August 2019, between 18:00 and up to 30 minutes before each individual start time.

Access to the holding area is limited to team members and media representatives with appropriate identification.

12.3 Start of the rally

The start of the competitive element of the rally will be given on Thursday, 22 August 2019, from TC 0 SP Bostalsee (see Itinerary). Time cards will be issued at TC0.

12.4 Finish procedure

The competitive element of the rally will conclude at TC 19C (Holding Area Bostalsee).

From this point, all cars are subject to parc fermé rules until the parc fermé is opened at the instruction of the stewards.

After the conclusion of the Rally at TC 19C, all classified cars shall be driven to the finish procedure at the podium Service park Bostalsee as instructed by the officials.

After the finish ceremony, all rally cars (except the cars selected for final scrutineering) must follow the marshals' instructions to proceed to the final parc fermé service park Bostalsee.

The cars selected for final scrutineering will be guided by the organiser in convoys to final scrutineering. Each competitor may nominate a person to drive the rally car under the organiser's control to the final parc fermé/or to final scrutineering.

Access to the holding area in front of the finish podium will be limited to officials and to media representatives holding the appropriate pass.

Only upon presentation of the parc fermé pass issued with the rally materials may a car be removed from the final parc fermé by the drivers or their representatives, once the stewards have authorised to open the final parc fermé.

12.5 Any special procedures / activities including the organisers' promotional activities

Thursday	22 August 2019	14:00hrs	Meet the Crews, Service Park
Sunday	25 August 2019	From 14:00hrs	Ceremonial finish Service park Bostalsee

12.6 Start Order and Starting Intervals

12.6.1 The Start order of the rally will be as follows:

- TC 0 Service Parc Bostalsee: P2P drivers and P1 in reversed order of the championship classification, P2, RGT and non priority drivers in their respective numerical order.
- Friday, Saturday and Sunday: according to Art. 45.2 of 2019 FIA WRC Sporting Regulations

12.6.2 SS 4/7 Wadern-Weiskirchen

During Sections 2 and 3 there will be the **SS Wadern-Weiskirchen**, organised in form of a “circuit special stage”. The number of laps as detailed in the road book must be completed before the drivers leave the course to the flying finish and to the Stop control.

The competitors are themselves responsible to respect the number of laps which are clearly indicated in the Road Book.

If the number of laps is exceeded, the time set, including all completed laps, will be counted. If the number of laps completed is below the prescribed number, the crew is considered to have failed to complete the section and Article 46 of the 2019 FIA WRC Sporting Regulations will apply.

Start procedure:

- At the start of these stages, a manual start procedure will be used. After handing back the time card to the crew, the timekeeper will count down aloud: 15”, 10” and the last 5 seconds one by one. When the last five seconds have elapsed, the starting signal will be given whereupon the crews shall immediately start into the special stage.
- The actual starting time (hour, minute, second and tenth of a second) recorded on the starting line by photocell will be entered on the Time Card at the SS Stop Point. For the start time as per Article 33.3.5 of the 2019 FIA WRC Sporting Regulations, only the hour and minutes shall be taken into consideration.
- All crews which have been allocated a start time interval of 2 minutes at the start of Section 1, 2 and 3 will have at least an interval of 1.40 minutes between their start time and the start time of any other crew. All other crews will have at least an interval of 40 seconds between their start time and the start time of any other crew.

If the running of SS 4/7 is interrupted, this will be signalled to the drivers by red flags. When given this signal, the driver must immediately reduce speed and leave the SS to the finish, even if the prescribed number of laps is not completed. Failure to comply with this rule will entail a penalty at the discretion of the Stewards.

12.7 Official time used during the rally

The official time used during the rally is the speaking clock of the “Deutsche Telekom”: Telephone 0180 4 100 100 (0.20 Euro per call).

12.8 Flexi Service

12.8.1 Flexi Service for P1-drivers

In accordance with FIA WRC Sporting Regulations Art 51.2.

12.8.2 Flexi Service for P2P, P2, RGT-drivers and drivers without FIA priority

In accordance with FIA WRC Sporting Regulations Art 51.3.

12.9 Permitted early check in

Crews are authorised to check in early without incurring a penalty at TC 1 A (end of section 1), TC 7 C (end of section 3), TC 15 C (end of section 7) and TC 19 C (end of section 10).

12.10 Service Park

12.10.1 Admission

Only cars carrying the appropriate car identification passes will be admitted in the service park.
Any parking of service and/or auxiliary vehicles in the service park outside the designated service area allocated to each team is strictly prohibited.

12.10.2 Environmental prescriptions:

The compliance with the environmental and safety prescriptions will be carefully checked by officials. Please make sure that all team members are aware of these prescriptions.

- The service park is located in a sensible water protection area adjacent to an integral nature reserve. Contemporary motorsport means also that organiser and participants undertake all efforts to protect the environment – in particular water and soil.

- **Cleaning of vehicle components**

Several facilities (water containers and water connection) will be available in the service park nearby the service park headquarters from Tuesday, 20 August 2019. **The use of high-pressure cleaners or water hoses for cleaning purposes is prohibited at all other locations in the area of the service park.**

- The crews are obliged to put a sufficiently large plastic ground sheet under the competition car as long as service works are carried out on the car. The ground sheet must be sufficiently strong and tear-resistant, have no damages and be tight, i.e. impervious to oil, fuel, cooling and brake liquids as well as to battery acid. If several sheets are connected, this connection must be made of adhesive tape which is leak-tight, impervious and tear-resistant to the aforementioned substances or an overlap of the sheets of at least 50 cm must be ensured.

Any residues such as water, oil, fuel, any other liquids, dirt and similar must be collected from the ground sheets, the use of wet vacuum cleaners is recommended, and be disposed environmentally-friendly (e.g. into the containers at the high-pressure cleaners facilities provided by the organiser).

- The crews are required to see that no substances hazardous to water pass over the edge of the ground sheet and into the ground, even in the case of rain.

- The service crews must be in possession of oil absorbing materials and have available a container for used oil and brake fluid at any time during the event.

- Any pollution of the environment must be avoided. Any waste, wrapping material, spare parts, empty oil or colour tins, batteries, etc. must be collected and given to a waste disposal by the competitors themselves. Used oil must be collected and brought to the containers made available in the service park for this purpose.

- Containers with substances hazardous to water such as oil, fuel, cooling and brake liquids, chemical substances or cleaning agents must not contain more than 20 litres per unit. No more than 100 litres of the above substances may be stored inside a vehicle if no safety devices such as collecting tray are provided.

Any such empty containers must be disposed at the collection points for hazardous goods inside the service park and/or with TOTAL Additifs et Carburants Speciaux for fuel containing devices.

- To enable a smooth operation of the rescue teams in case of an accident, all containers with liquid and non-liquid chemicals (e.g. cleaning agents) must carry labels which clearly identify their contents.

- Smoking is forbidden at a distance of less than 10m from containers with inflammable contents (e.g. fuel for generators), even if the containers have been emptied. A solid barrier must be provided between the storage area of any such containers and eventual spectator areas before, during and after their use.

- The ban to impair the environment, e.g. water, soil and biotope, is also regulated in the national environmental and criminal law.

Any infringement will be reported to the Stewards.

12.10.3 Cash Deposit

Each area in the service park must be left in a clean condition and without any rubbish. Before leaving the service park, each competitor must report to the service park headquarters staff during the service park opening hours to get clearance for the corresponding area. On Sunday, 25 August 2019, the staff will be available until 20:00hrs and on Monday, 26 August 2019, between 08:00 and 12:00hrs (or upon special agreement).

Please note that for this purpose, a cash deposit of 100 € for each competitor and industry will be required at Administrative Checks. Each competitor will get a corresponding receipt and this deposit will be reimbursed by the service park HQ staff upon submission of this receipt and after clearance of the competitor's service park area.

12.10.4 Car wash facility

A rally car wash facility will be available on Thursday (Shakedown), Friday, Saturday and Sunday each time prior to the cars entering the regroup area/service park Bostalsee. See Road Books for exact locations.

12.10.5 Fuel tank calibration zone

For the use until Thursday, 22 August 2019, a fuel tank calibration zone nearby the refuel area at the service park Bostalsee will be provided. Any emptying or refilling of fuel in the area of the service park Bostalsee may only be carried out in this zone and under the competitors' own responsibility.

12.10.6 Dismantling of facilities

Any dismantling of service area facilities before Sunday, 25 August 2019, 15:30hrs, must be made at times when there is no rally traffic inside the service park (see Itinerary) unless any such dismantling is exclusively carried out within the periphery of the corresponding team area itself (without using any kind of traffic lanes or team external areas).

12.11 Route Note Cars

12.11.1 General

As detailed in the 2019 FIA WRC Sporting Regulations, Article 11.6.

12.11.2 Identification

All these cars will be identified by the organiser.

12.11.3 Registration

The registration form for these cars must be submitted to the organiser as detailed under point 3.2 of these Regulations.

12.11.4 Special prescriptions

- A speed limit of 90 km/h is imposed in the special stages. All national traffic rules must be respected on the special stages and on the road sections between the special stages. The route note car crews must proceed with care, at a reduced speed, in the same direction as the rally.
- Any infringement of these provisions will result in the immediate withdrawal of the specific identification issued by the Organisers, without prejudice to any other sanction imposed at the Stewards' discretion.

12.11.5 GPS tracker system for route note cars

All route note cars must be equipped with the speed control device as used during reconnaissance. The provider is STATUS AWARENESS SYSTEMS (SAS).

Return: Sunday 25th August 2019, no later than 13.00 hrs – SAS truck – Service Park Bostalsee

12.11.6 Route Note Car exchange points

Will be communicated by a bulletin.

12.12 Regrouping St. Wendel (Saturday)

Article 42.5.2 of the 2019 FIA WRC Sporting Regulations is not applicable for the Regroup St. Wendel.

12.13 Power Stage (SS 19 – Dhronal)

With reference to Art. 13.3 in the 2019 FIA WRC Sporting Regulations special stage 19 Dhronal will be run as the "Power Stage".

13. IDENTIFICATION OF OFFICIALS

The post chiefs and other officials will be identified as follows:

Post Chiefs:	White tabards, "CONTROL" in red letters
Special Stage Commanders:	Red tabards, "STAGE CHIEF" in white letters
Track Marshals:	Yellow tabards, "MARSHAL" in black letters
Spectator Marshals:	Blue tabards, "SAFETY" in black letters
Yellow flag Marshals:	Yellow tabards with black radio point symbol
Timekeepers:	Green tabards, "TIMEKEEPER" in white letters
Competitors' Relations Officers:	Red tabards, "RELATIONS OFFICER" in white letters

14. PRIZES

General Classification

The crews first, second and third overall plus the winning manufacturer will receive ADAC Honorary Cups.

Class Classification

30 % of the starters in each class which are not at the same time overall or FIA Support Championship event winners will receive cups, provided that the minimum of 5 cars have been entered in the corresponding class. Should this number not be attained, the competitors in the class concerned are admitted in the next class up.

FIA WRC 2 PRO, FIA WRC 2, RGT Championships for Drivers

The winning crew in each of these classifications will receive cups.

Other awards:

The organiser reserves the right to award additional prizes.

15. FINAL CHECKS AND PROTESTS

15.1 Final Checks

Location: Scrutineering building, Service park Bostalsee

Time: Sunday, 25 August 2019, after the podium ceremony.

The cars selected for final scrutineering will be informed in writing. They are requested to provide proper equipment (including all sealed spare parts) and technicians at the final scrutineering venue.

15.2 Protest fees

Sum of the protest fee: € 1,000 (see Article 55.2 of the 2019 FIA WRC Sporting Regulations).

If the protest requires the dismantling and the reassembly of different parts of a car, the claimant must pay an additional deposit which will be determined by the Stewards.

15.3 Appeal deposit

The international appeal deposit (FIA) is: € 6,000.

Appendix 1: ITINERARY (V3)

ADAC RALLYE DEUTSCHLAND		ITINERARY (V3) (19.06.2019)			FIA WRC FIA WORLD RALLY CHAMPIONSHIP	
Shakedown (Sunrise: 6:21, Sunset: 20:40) Thursday 22 August 2019						
TC/SS	LOCATION	SD dist.	Liaison dist.	Total dist.	Target time	1st car due
	Bostalsee (Service Park OUT)					
	St. Wendeler Land Shakedown		15,08	15,28		
SD	Shakedown Stage	5,20				10:00
	Bostalsee (Service Park IN)		12,44	17,64		
SHAKEDOWN TOTALS		5,20	27,52	32,92		

ADAC RALLYE DEUTSCHLAND		ITINERARY (V3) (19.06.2019)			FIA WRC FIA WORLD RALLY CHAMPIONSHIP	
Start Section 1 (Sunrise: 6:21, Sunset: 20:40) Thursday 22 August 2019						
TC/SS	LOCATION	SS dist.	Liaison dist.	Total dist.	Target time	1st car due
0	Start Bostalsee					18:45
1	St. Wendeler Land		15,08	15,08	00:20	19:05
SS 1	SSS St. Wendeler Land	5,20				19:08
1 A	Overnight Parc fermé & Technical Zone IN		12,44	17,64	00:30	19:38
THURSDAY TOTALS		5,20	27,52	32,72		

ADAC RALLYE DEUTSCHLAND		ITINERARY (V3) (19.06.2019)				FIA WRC	
Re-Start Sections 2, 3 (Sunrise: 6:23, Sunset: 20:38) Friday 23 August 2019							
TC/ SS	LOCATION	SS dist.	Liaison dist.	Total dist.	Target time	1st car due	
1 B	Parc fermé OUT / Service IN (Bostalsee)					09:00	
	Service A (Bostalsee)	(5,20)	(27,52)	(32,72)	00:15		
1 C	Service OUT					09:15	
RZ	Refuel FIA Fuel						
1	Distance to next refuel	(41,44)	(80,35)	(121,79)			
2	Fell		47,84	47,84	00:56	10:11	
SS 2	Stein und Wein 1	19,44				10:14	
3	Trittenheim		28,19	47,63	00:51	11:05	
SS 3	Mittelmosel 1	22,00				11:08	
RZ	Remote Refuel FIA Fuel	4,32 km after finish SS 3)					
2	Distance to next refuel	(9,27)	(70,84)	(80,11)			
4	Morscholz		53,48	75,48	01:32	12:40	
SS 4	Wadern-Weiskirchen 1	9,27				12:43	
4 A	Regroup & Technical Zone IN		21,68	30,95	00:50	13:33	
4 B	Regroup OUT / Service IN				00:30	14:03	
	Service B (Bostalsee)	(50,71)	(151,19)	(201,90)	00:40		
4 C	Service OUT					14:43	
RZ	Refuel FIA Fuel						
3	Distance to next refuel	(41,44)	(80,35)	(121,79)			
5	Fell		47,84	47,84	00:56	15:39	
SS 5	Stein und Wein 2	19,44				15:42	
6	Trittenheim		28,19	47,63	00:51	16:33	
SS 6	Mittelmosel 2	22,00				16:36	
RZ	Remote Refuel FIA Fuel (Piesport -	4,32 km after finish SS 6)					
4	Distance to next refuel	(9,27)	(70,84)	(80,11)			
7	Morscholz		53,48	75,48	01:32	18:08	
SS 7	Wadern-Weiskirchen 2	9,27				18:11	
7 A	Parc fermé & Technical Zone IN		21,68	30,95	00:50	19:01	
7 B	Parc fermé OUT / Flexi Service IN				00:10	19:11	
	Flexi Service C (Bostalsee)	(50,71)	(151,19)	(201,90)	00:48		
7 C	Flexi Service OUT /Overnight Parc fermé IN					(19:59)	
All cars must be returned to Parc fermé no later than						23:00	
FRIDAY TOTALS		101,42	302,38	403,80			

SECTION 2

SECTION 3

ADAC RALLYE DEUTSCHLAND		ITINERARY (V3) (19.06.2019)			WRC FIA WORLD RALLY CHAMPIONSHIP	
Re-Start Sections 4, 5, 6, 7 (Sunrise: 6:25, Sunset: 20:36) Saturday 24 August 2019						
TC/ SS	LOCATION	SS dist.	Liaison dist.	Total dist.	Target time	1st car due
7 D	Parc fermé OUT / Service IN (Bostalsee)					07:15
	Service D (Bostalsee)	(0,00)	(0,00)	(0,00)	00:15	
7 E	Service OUT					07:30
RZ	Refuel FIA Fuel					
5	Distance to next refuel	(27,06)	(69,30)	(96,36)		
8	Berschweiler		25,36	25,36	00:36	08:06
SS 8	Freisen 1	14,78				08:09
9	Ottweiler		33,32	48,10	01:00	09:09
SS 9	Römerstraße 1	12,28				09:12
RZ	Remote Refuel FIA Fuel		10,62 km after finish SS 9)			
6	Distance to next refuel	(27,06)	(97,47)	(124,53)		
9 A	Regroup St. Wendel IN		13,34	25,62	00:47	09:59
9 B	Regroup St. Wendel OUT				00:30	10:29
10	Berschweiler		26,46	26,46	00:37	11:06
SS 10	Freisen 2	14,78				11:09
11	Ottweiler		33,32	48,10	01:00	12:09
SS 11	Römerstraße 2	12,28				12:12
11 A	Regroup & Technical Zone IN		34,97	47,25	01:04	13:16
11 B	Technical Zone OUT / Service IN				00:15	13:31
	Service E (Bostalsee)	(54,12)	(166,77)	(220,89)	00:40	
11 C	Service OUT					14:11
RZ	Refuel FIA Fuel					
7	Distance to next refuel	(51,90)	(90,25)	(142,15)		
12	Lager Aulenbach		43,32	43,32	00:54	15:05
SS 12	Arena Panzerplatte 1	10,73				15:08
13	Reichenbach		7,64	18,37	00:35	15:43
SS 13	Panzerplatte 1	41,17				15:46
13 A	Regroup & Technical Zone IN		39,29	80,46	01:25	17:11
13 B	Technical Zone OUT / Service IN				00:30	17:41
	Service F (Bostalsee)	(51,90)	(90,25)	(142,15)	00:15	
13 C	Service OUT					17:56
RZ	Refuel FIA Fuel					
8	Distance to next refuel	(51,90)	(89,54)	(141,44)		
14	Lager Aulenbach		43,32	43,32	00:54	18:50
SS 14	Arena Panzerplatte 2	10,73				18:53
15	Reichenbach		7,64	18,37	00:35	19:28
SS 15	Panzerplatte 2	41,17				19:31
15 A	Parc fermé & Technical Zone IN		39,29	80,46	01:25	20:56
15 B	Parc fermé OUT / Flexi Service IN				00:10	21:06
	Flexi Service G (Bostalsee)	(51,90)	(90,25)	(142,15)	00:48	
15 C	Flexi Service OUT /Overnight Parc fermé IN					(21:54)
	<i>All cars must be returned to Parc fermé no later than</i>					01:00
SATURDAY TOTALS		157,92	347,27	505,19		

ADAC RALLYE DEUTSCHLAND		ITINERARY (V3) (19.06.2019)				FIA WRC FIA WORLD RALLY CHAMPIONSHIP	
Re-Start Sections 8, 9, 10 (Sunrise: 6:26, Sunset: 20:33) Sunday 25 August 2019							
TC/SS	LOCATION	SS dist.	Liaison dist.	Total dist.	Target time	1st car due	
15 D	Parc fermé OUT / Service IN					06:20	
	Service H (Bostalsee)	(0,00)	(0,00)	(0,00)	00:15		
15 E	Service OUT					06:35	
RZ 9	Refuel FIA Fuel						
	Distance to next refuel	(28,06)	(72,85)	(100,91)			
16	Wintrich		62,18	62,18	01:08	07:43	
SS 16	Grafschaft 1	28,06				07:46	
RZ 10	Remote Refuel FIA Fuel (Morbach)	10,67 km after finish SS 16)					
	Distance to next refuel	(39,75)	(46,94)	(86,69)			
16 A	Regroup & Technical Zone Morbach IN		10,80	38,86	00:55	08:41	
16 B	Regroup & TZ Morbach OUT				00:30	09:11	
17	Dhrontal		24,45	24,45	00:27	09:38	
SS 17	Dhrontal 1	11,69				09:41	
18	Wintrich		11,69	20,94	00:26	10:07	
SS 18	Grafschaft 2	28,06				10:10	
RZ 11	Refuel FIA Fuel (Morbach)	10,67 km after finish SS 18)					
	Distance to next refuel	(11,69)	(97,90)	(109,59)			
18 A	Regroup Morbach IN		10,80	38,86	00:55	11:05	
18 B	Regroup Morbach OUT				00:40	11:45	
19	Dhrontal		24,45	24,45	00:30	12:15	
SS 19	Dhrontal 2	11,69				12:18	
19 A	Technical Zone IN		62,65	74,34	01:02	13:20	
19 B	Service IN				00:03	13:23	
	Service J (Bostalsee)	(79,50)	(207,02)	(286,52)	00:10		
19 C	Service OUT /Finish TC and Holding Area Bostalsee					13:33	
	Podium from					(14:00)	
SUNDAY TOTALS		79,50	207,02	286,52			
TOTALS OF THE RALLY							
		SS	Liaison	Total	* %		
Thursday (Section 1) - 1 SS		5,20	27,52	32,72	15,9		
Friday (Sections 2, 3) - 6 SS		101,42	302,38	403,80	25,1		
Saturday (Sections 4, 5, 6, 7) - 8 SS		157,92	347,27	505,19	31,3		
Sunday (Sections 8, 9, 10) - 3 SS		79,50	207,02	286,52	27,7		
TOTAL		344,04	884,19	1228,23	28,0		

Appendix 2:
RECCE SCHEDULE (V2)

ADAC RALLYE DEUTSCHLAND	RECCE SCHEDULE (V2) (19.06.2019)	
--------------------------------	--	--

Recce Day 1 **Tuesday, 20.08.2019**

Group 1 FIA P1/P2		Allowed time	SS km	SS km x2	Finish 1 > > Start 2	To next SS	Total km
Service Park	Bostalsee					47,84 (SS 2/5)	47,84
SS 2/5	Stein und Wein	08:00 - 13:00	19,44	38,88	19,65	27,86 (SS 3/6)	86,39
SS 3/6	Mittelmosel	08:00 - 13:00	22,00	44,00	4,80	9,79 (SS 16/18)	58,59
SS 16/18	Grafschaft	12:00 - 17:00	28,03	56,06	17,24	34,90 (SS 17/19)	108,20
SS 17/19	Dhrontal	12:00 - 17:00	11,69	23,38	17,15	51,22 (SS 4/7)	91,75
SS 4/7	Wadern-Weisk.	14:00 - 19:00	9,27	18,54	4,42	21,41 (Bostalsee)	44,37
							437,14

Group 2 FIA P3/Non-Priority		Allowed time	SS km	SS km x2	Finish 1 > > Start 2	To next SS	Total km
Service Park	Bostalsee					62,18 (SS 16/18)	62,18
SS 16/18	Grafschaft	08:00 - 13:00	28,03	56,06	17,24	34,90 (SS 17/19)	108,20
SS 17/19	Dhrontal	08:00 - 13:00	11,69	23,38	17,15	28,48 (SS 2/5)	69,01
SS 2/5	Stein und Wein	12:00 - 17:00	19,44	38,88	19,65	27,86 (SS 3/6)	86,39
SS 3/6	Mittelmosel	12:00 - 17:00	22,00	44,00	4,80	53,18 (SS 4/7)	101,98
SS 4/7	Wadern-Weisk.	16:00 - 19:00	9,27	18,54	4,42	21,41 (Bostalsee)	44,37
							472,13

Recce Day 2 **Wednesday, 21.08.2019**

Group 1 FIA P1/P2		Allowed time	SS km	SS km x2	Finish 1 > > Start 2	To next SS	Total km
Service Park	Bostalsee					25,36 (SS 8/10)	25,36
SS 8/10	Freisen	08:00 - 14:00	14,78	29,56	7,37	33,05 (SS 9/11)	69,98
SS 9/11	Römerstraße	08:00 - 14:00	12,28	24,56	23,13	19,75 (SSS1 / SD)	67,44
SSS 1/SD	St. Wendeler Land	10:00 - 15:00	5,17	10,34	12,77	41,02 (SS 12/14)	64,13
SS 12/14	Arena Panzerplatte	13:00 - 17:00	10,73	21,46	7,44	7,44 (SS 13/15)	28,90
SS 13/15	Panzerplatte	13:00 - 17:00	41,17	82,34	4,42	38,99 (Bostalsee)	125,75
							381,56

Group 2 FIA P3/Non-Priority		Allowed time	SS km	SS km x2	Finish 1 > > Start 2	To next SS	Total km
Service Park	Bostalsee					15,08 (SSS 1/SD)	15,08
SSS 1/SD	St. Wendeler Land	08:00 - 11:00	5,17	10,34	12,77	41,02 (SS 12/14)	64,13
SS 12/14	Arena Panzerplatte	08:00 - 14:00	10,73	21,46	7,44	7,44 (SS 13/15)	28,90
SS 13/15	Panzerplatte	08:00 - 14:00	41,17	82,34	4,42	14,49 (SS 8/10)	101,25
SS 8/10	Freisen	13:00 - 17:00	14,78	29,56	7,37	33,05 (SS 9/11)	69,98
SS 9/11	Römerstraße	13:00 - 17:00	12,28	24,56	23,13	34,65 (Bostalsee)	82,34
							361,68

The time window of reconnaissance for each group is compulsory, the order of the stages within this window is free.

**Appendix 3:
COMPETITORS RELATIONS OFFICERS – PROGRAMME**

MONDAY, 19.08.2019		
14:00–20:00	Administrative Checks (Rally HQ Bostalsee)	Riedemann
TUESDAY, 20.08.2019 and WEDNESDAY, 21.08.2019 during Recce Christian Riedemann and/or Charly Beck will be available at various points on the special stages.		

WEDNESDAY, 21.08.2019		
15:00–End	Scrutineering (Service park Bostalsee, Building next to FIA fuel)	Kaspar -Riedemann-Beck
16:00	WRC Manufacturers-Team-Managers Meeting, Rally HQ – Victor’s Seehotel Bostalsee – Organizers meeting room	Beck

THURSDAY, 22.08.2019		
10:00–15:30	Shakedown (Start)	Beck-Kaspar-Riedemann
16:00	Publication of start lists for section 1 and section 2 (Official Notice Board)	Schleimer - Beck
From 18:00	Holding Area SP Bostalsee	Riedemann - Kaspar
From 19:30	TC1A Parc fermé IN, Bostalsee	Schleimer - Riedemann

FRIDAY, 23.08.2019		
From 08:45	TC1B Start of Section 1 (Bostalsee – Parc Fermé)	Beck
All day: Service park Bostalsee, and in particular:		
From 13:30	TC4A Regrouping / Technical Zone IN	Riedemann - Schleimer
From 19:00	TC7A Regrouping / Technical Zone IN	Beck - Kaspar

SATURDAY, 24.08.2019		
From 07:15	TC1B Start of Section 4 (Bostalsee – Parc Fermé)	Riedemann
From 09:45	TC9A Regrouping St. Wendel	Beck - Schleimer
All day: Service park Bostalsee, and in particular:		
From 13:00	TC11A Regrouping / Technical Zone IN	Riedemann - Kaspar
From 17:00	TC13A Regrouping / Technical Zone IN	Beck - Schleimer
From 20:45	TC15A Regrouping / Technical Zone IN	Kaspar – Beck - Riedemann

SUNDAY, 25.08.2019		
From 06:10	TC15D Start of Section 8 (Bostalsee – Parc Fermé)	Beck
From 06:35	TC15E Service G: Service OUT	Riedemann
From 08:30	TC16A Regrouping / Technical Zone Morbach IN	Schleimer - Beck
From 11:00	TC18A Regrouping / Technical Zone Morbach IN	Schleimer - Beck
From 13:00	TC 19A Technical Zone IN	Riedemann
From 13:15	TC19C Finish TC and Holding Area Bostalsee (Service park)	Kaspar – Riedemann - Schleimer
After Podium	Final Scrutineering (Scrutineering Building)	Riedemann-Schleimer
16:00	Publication of provisional classification (Official Notice Board)	Kaspar



Charly BECK
Contact: +49 172 6282480



Christian RIEDEMANN
Contact: +49 151 41804917



Josef KASPAR
Contact: +49 151 20796456



Simone SCHLEIMER
Contact: +49 151 54442952

**Appendix 4:
DOOR PLATES, COMPETITION NUMBERS AND DRIVERS' NAMES**

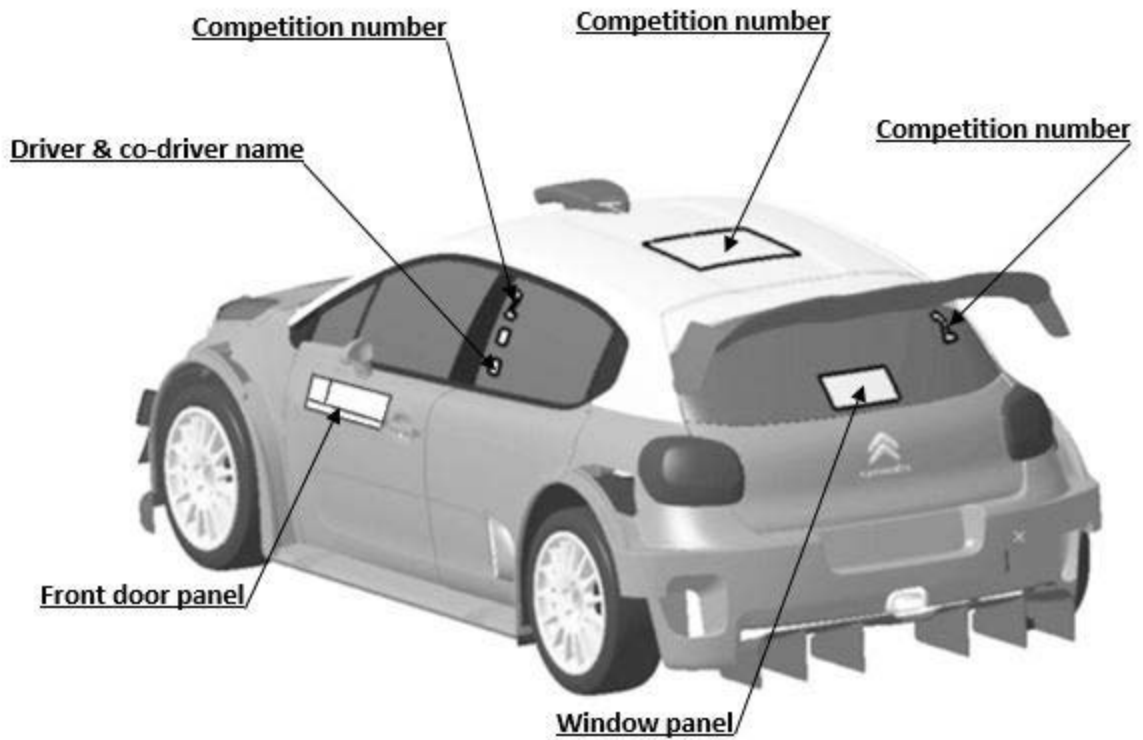
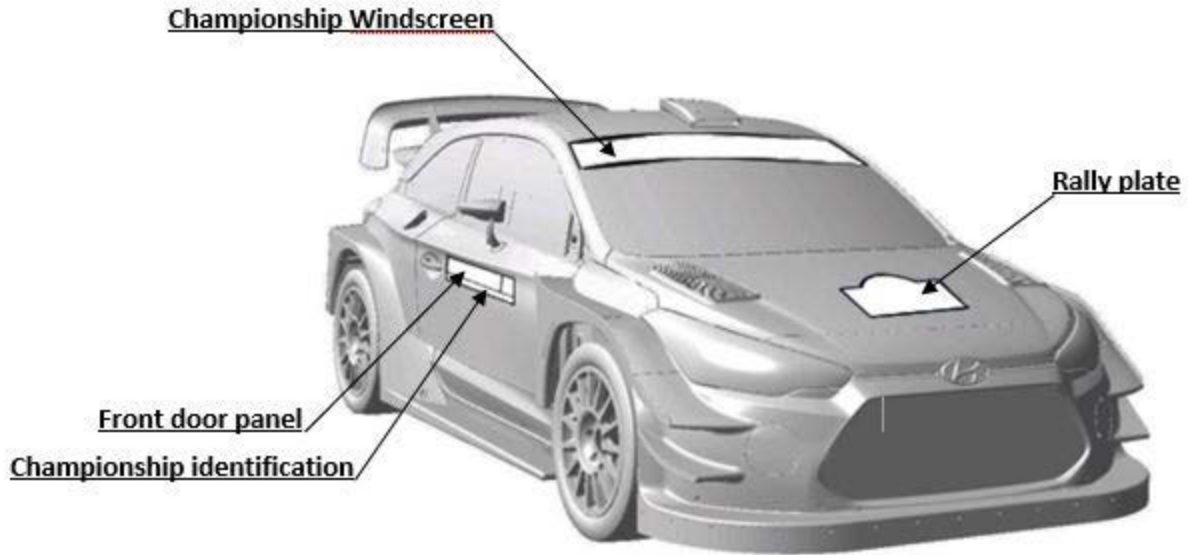

Appendix 5: REMINDERS FIA APPENDIX L

All the competitors and drivers are reminded of the Appendix L to the 2019 FIA International Sporting Code, in particular regarding Chapter III – Drivers' Equipment (Helmets, flame-resistant clothing, frontal head restraint (FHR) and safety belts).

Link:

<https://www.fia.com/regulation/category/123> (Chapter III page 19)

<https://www.fia.com/regulation/category/761> (Technical list)

These regulations apply to Shakedown as well (helmet specifications, clothing comprising overalls, gloves (optional for co-drivers), long underwear, a balaclava, socks and shoes homologated to the FIA 8856-2000 standard).

HELMETS:

P1 drivers must wear crash helmets which meet the FIA Standard 8860-2018 or 8860-2018-ABP–Advanced Helmet Test Specification (FIA Technical List n°69).

All others drivers must wear crash helmets homologated to one of the standards listed in FIA Technical List n°25, but are also compatible with FHR system, so are approved in accordance with FIA standard 8858 (Technical List n°41), 8860 (Technical List n°33) or 8859 (Technical List n°49). However, it is strongly recommended that they wear helmets meeting the FIA 8860 standard.

FRONTAL HEAD RESTRAINT (FHR):

The use of FIA approved FHR system is mandatory for all crews.

The wearing of any device intended to protect the head or neck and attached to the helmet is prohibited, unless the device has been homologated according to the FIA Technical List n°29.

FLAME RESISTANT CLOTHING REMINDER: All crews must wear overalls, gloves (optional for co-drivers), long underwear, a balaclava, socks and shoes homologated to the FIA 8856-2000 standard (FIA Technical List n°27) or FIA 8856- 2018 standard (Technical list N° 79).

**Appendix 6:
WRC TRACKER FITTING KIT INSTRUCTIONS**

Page | 1



SAS Fitting Kit Manual – RALLY CAR

Welcome

This manual is provided as a guide for the installation of the WRC Tracking System Kit, for competition vehicles only. Care should be taken when considering the location of components with regard to electrical cabling and fire suppression systems already installed in the vehicle. Please check always that the components of your kit are as requested.

Table of Contents

1. Tracking Unit Kit Components	3
2. Power Supply.....	3
3. Connection Diagram	3
4. Tracking Unit Dimensions	4
5. Tracking Unit Mounting	5
6. Antenna Installation	6
6.1 External Antenna Installation	7
6.2 Internal Antenna Installation	8
7. Contact	8

1. Tracking Unit Kit Components

The WRC Tracking System Kit includes:

- WRC Tracking Installation and Fitting Kit Instruction Sheet;
- 3-in-1 antenna with leads;
- Internal radio antenna with lead;
- 6 – 24v wiring loom with plug;
- Mount, to be bolted to tunnel;
- Adjustable mount connector/knuckle.



(Contents may differ slightly to image shown)

2. Power Supply

WRC tracking system requires a reliable power supply from 9 to 28 volts DC. We recommend a 5 amp (Max) blade type or similar quality fuse is used at the battery supply end of the WRC tracking system power lead.

Zero volts or battery negative can be picked up at any suitable earthing point providing the isolation switch does not switch the negative side of the battery.

The WRC tracking system unit has an internal battery that is kept charged via the car's power supply. It acts as a reserve supply to power the unit in the case of an accident where a car's power supply is interrupted (e.g. car battery smashed or dislodged).

3. Connection Diagram

The 6-24v wiring loom, includes five wires. The white blue and grey wires must be stagger cut and heat shrunk or taped back so they cannot short to ground or to each other. Red and black are used as follows:

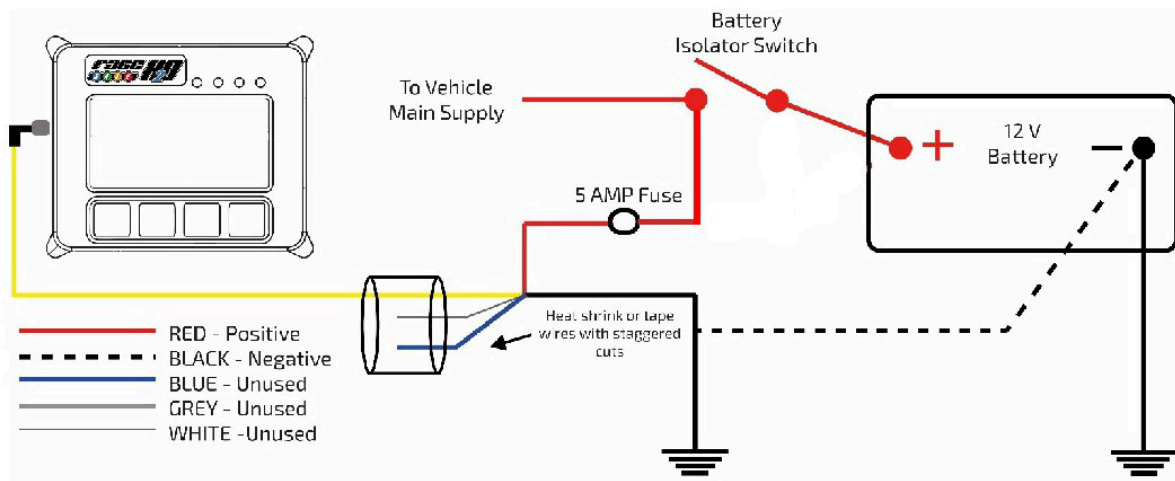

RALLYSAFE 12V WIRING DIAGRAM

During installation, the wiring loom should be routed away from the engine compartment, Ignition or Alternator wiring.

300 mm of Power Supply Wiring Loom is required to be available for connection to the WRC Tracker Unit at the mounted position.

4. Tracking Unit Dimensions

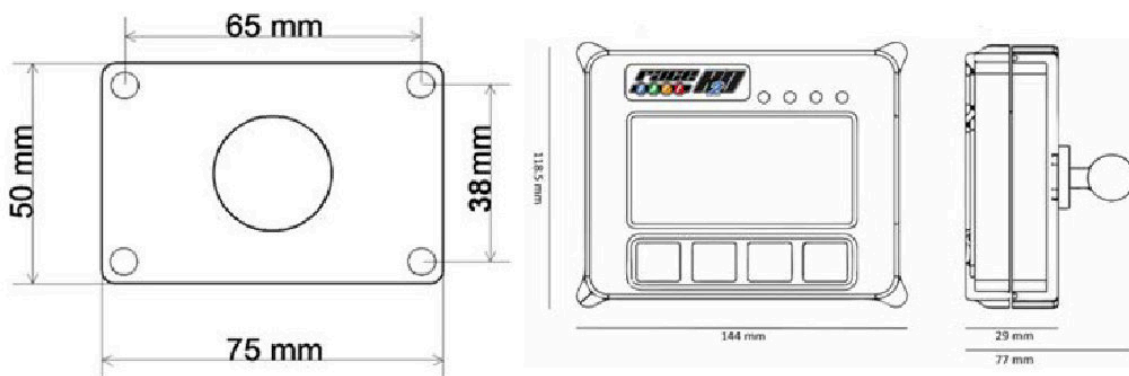

5. Tracking Unit Mounting

The preferred location and mounting for the WRC tracking system unit is a RAM style 50mm x 75mm flat base with ball, bolted through the tunnel with four **M6** Bolts.

It should be in a central, protected location on the central tunnel in front of the seats and both easily visible and accessible by both the driver and co-driver/nav.

Care should be taken when considering the location of the Mounting Point with regard to electrical cabling and fire suppression systems installed in the vehicle.

Photographs of mounting and positioning can be seen in Fig.1 and Fig.2 respectively.

Alternatively, the WRC tracking system unit can be mounted in a central protected location on the vehicle dashboard that is easily visible and accessible by both the driver and co-driver.

Mounting is a Ram style 50mm x 75mm flat base with ball, bolted with four **M6** bolts through the dashboard and a compulsory 3mm backing plate measuring no less than 145mm x 120mm

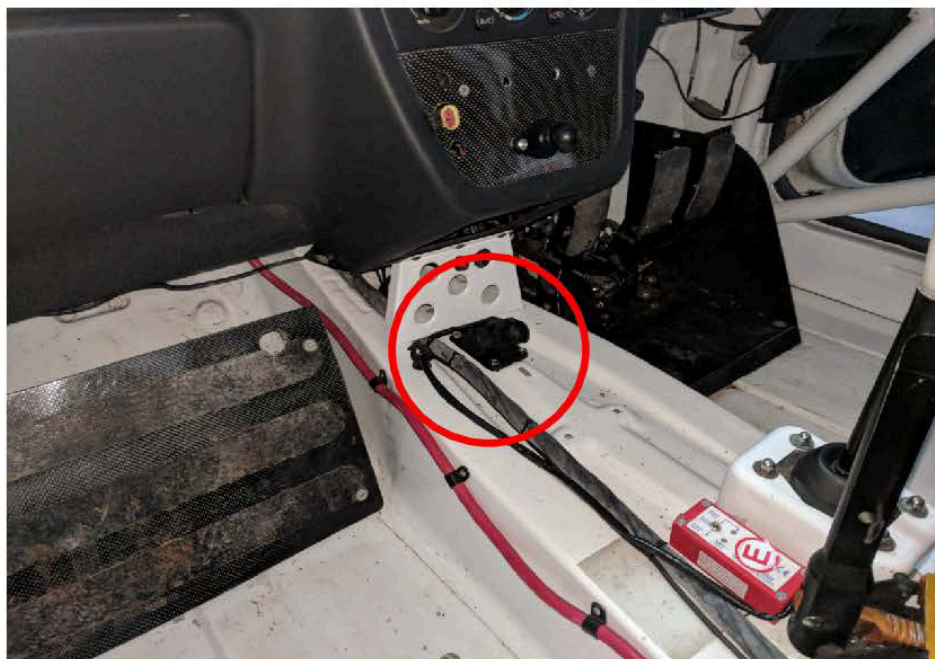

Figure 1. 25mm rubber ball securely attached to the tunnel

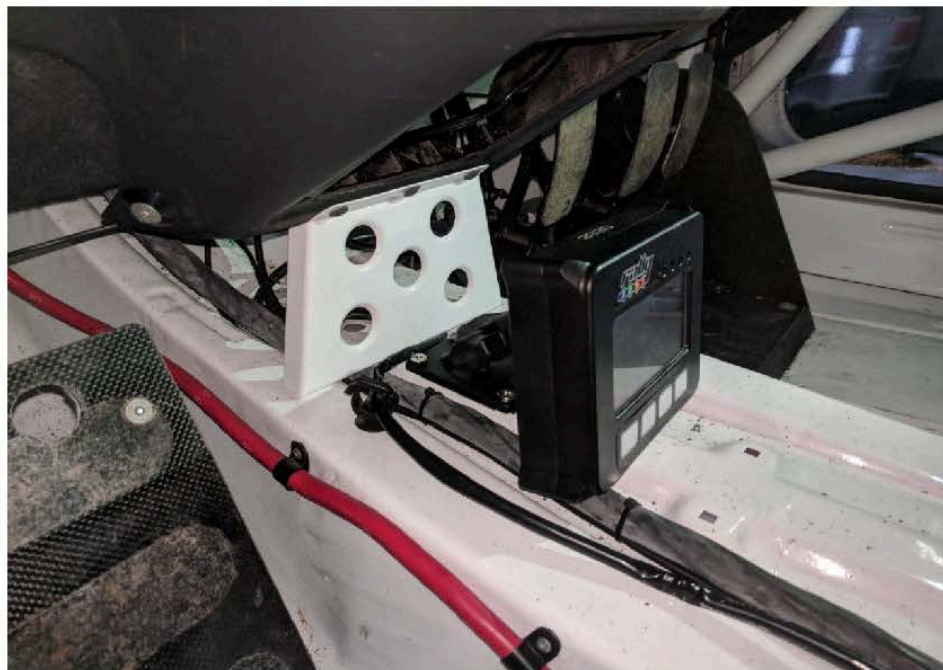

Figure 2. The WRC tracking unit mounted onto the 25mm rubber ball mount and connected through the RallySafe connector

6. Antenna Installation

All leads on both external and internal antennas must run on the inside of all roll cage bars. This is to stop cable crushing on impact.

Antenna must not be mounted within 200 mm of any high frequency antenna's or cabling

The preferred route is to go down from the antenna, underneath the closest part of the roll cage (roof cross or main hoop), follow that along to the roof hoop, then go down the inside A pillar to the unit. Please allow 200mm clearance of high frequency antenna or cabling

Any excess cable must be run so that the cable is not bent any tighter than a 100mm radius. We recommend running it across the underside of the dash and back (do not coil in tight loops).

Cables must be tied neatly along the whole installation all the way to the unit so they can't be accidentally caught or dislodged.

All this will be checked at scrutineering and you may be required to fix it before your car can pass.

6.1. External Antenna

The antenna is mounted through a 12mm hole in a central location on the ROOF of the vehicle, rear of the main roll bar hoop, allowing the cabling to pass through the roof and follow the cage bars back to the unit location. The antenna is a fully watertight unit, which seals against the roof surface.



Antenna leads are connected as follows (There may be variations with the type and number of leads).

1. The 2 UHF leads, colour-coded **Blue**, is connected to the terminal labelled "UHF" on the WRC unit (Right Hand Thread). Terminals are located of the rear of the unit and/or colour-coded Blue.
2. The Satellite Communication antenna lead is connected to the center or rear terminal labelled "IRI" (Left Hand Thread). It may also be colour-coded **Yellow** (this may be not marked on the 2-in-1 antenna).
3. The GPS antenna lead labelled "GPS", is connected to the terminal labelled "GPS" on the WRC unit (Right Hand Thread). Terminals may be on the side or rear of the unit and/or colour-coded **Green**.
4. GSM, has a small stick antenna supplied with the WRC unit, and is connected to corresponding terminal labelled "GSM" on the WRC unit (Left Hand Thread). The terminal is located on the rear of the unit and/or colour-coded **Red**.

6.2. Internal Antenna

The Internal Antenna should be placed on the inside of the ROOF in a clear uncluttered area, with a 200mm radius clear of any bar work or solid metal object. The internal antenna has a magnetic base with double-sided tape for adhesion. The cable is then run to the WRC unit. Please keep cable on the inner side of the roll cage pipework so as not to be crushed in the event of an accident.

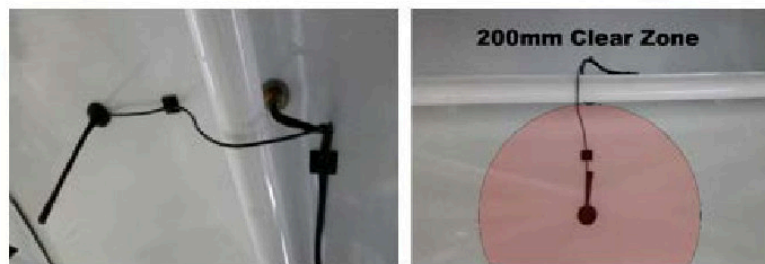

Figure 3. The internal antenna must be at least 200mm away from any roll cage components

7. Contact Us

For assistance, please contact the RallySafe Support Team by emailing: support@rallysafe.com.au

Product Disclaimer

"This manual, the specifications, and the material contained in it, as released by Status Awareness Systems and RallySafe, is for the purpose of information only. Due to continuous ongoing development, information and specifications may change at any time without notice. SAS, and the companies that have contributed to it, shall not be liable for any use of the manual or information supplied.

The material contained in this manual is protected by copyright and other types of Intellectual Property Rights. The commercial exploitation of the material contained in this specification requires a license to such Intellectual Property Rights.

This manual may be utilised or reproduced without any modification, in any form or by any means, for informational purposes only. For any other purpose, no part of the specification may be utilised or reproduced, in any form or by any means, without permission in writing from SAS.

The word RallySafe and the RallySafe logo are registered trademarks".

**Appendix 7:
SAS TRACKER COMPETITOR USER MANUAL**

Page | 1



SAS Tracker Competitor User Manual

Welcome

For your and other competitor's safety, it is important that you are familiar with the use of the WRC tracking unit, herein referred to as "the unit" or "the WRC tracking unit".

The SAS System is designed to increase competition safety by providing safety notifications to inform event management, improve response times and provide accurate and reliable event times.

The following document outlines the basic features and functions of the WRC tracking unit. Please note that the WRC Tracking unit must be fitted and connected in all competitor's car, in accordance with the SAS Fitting Kit Manual – RALLY CAR.

Table of Contents

1. Powering The Unit On	3
2. Stage Modes	3
2.1. Transport Mode	3
2.2. Stage Mode.....	4
3. Hazard Alerts.....	6
4. Red Flag	8
5. Transport Menu	9
5.1. Stage Times.....	10
5.2. Manual Hazard.....	11
6. Contact Us.....	11

1. Powering The Unit On

The unit is pre-loaded with all of the stage coordinates and is activated when powered on. Please power the unit on early before the event to give it time to run checks.

When powered on the unit will display the transport mode, the details of which are specified in the Art. 2.1 of this document.

The unit does not need to be powered off at any stage during the event as it will go to sleep within a few minutes of inactivity but can be re-woken by either moving the vehicle or pressing any of the four buttons.

It is recommended that the unit is not powered off during the event, to ensure the internal battery stays fully charged for emergencies.

2. Unit Modes

The unit has two modes:

- When not in a competitive stage, the unit will be in **transport mode**, as described in 2.1.
- When in a competitive stage, the unit will go into **stage mode**, as described in 2.2.

2.1. Transport Mode

SCREEN 1 – The transport mode displays from the top down the following information: the name of the next point you are travelling to, the time in transit, current time, accumulative and intermediate distances and speed, average speed.

The unit has four white physical buttons. Their functions is reported on the screen right above the button's location.

Starting from the far left button to the right, you have the following options:

- **OPTIONS**: Operation described in 5.Transport Menu.
- **BRIGHT**: Increase the screen brightness (Note that the screen must always be clearly readable so full brightness is recommended for daytime).
- **DIM**: Decrease the screen brightness,
- **RESET**: Intermediate trip meter.

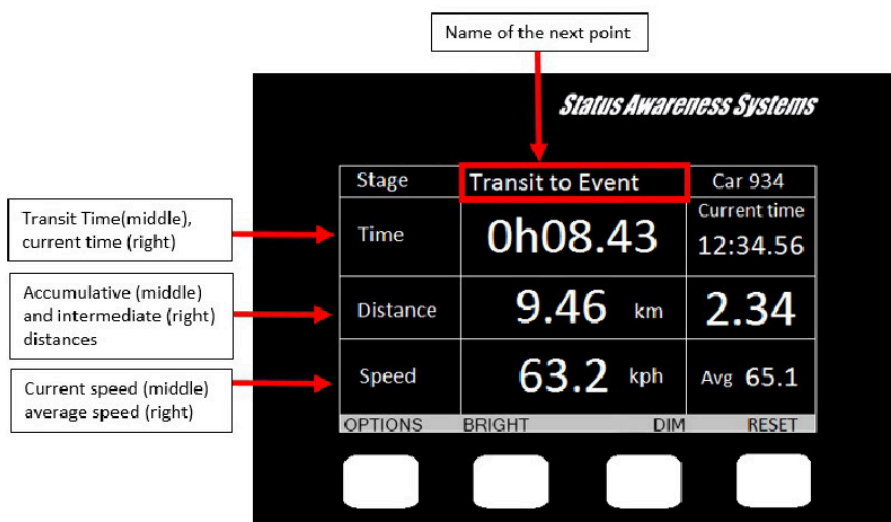

SCREEN 1. Transport Mode

2.2. Stage Mode

SCREEN 2 – When the start official assigns each individual competitor a due start time, a countdown will display on the unit as shown in the white field below. Also shown in the white field is the stage number and the due start time.

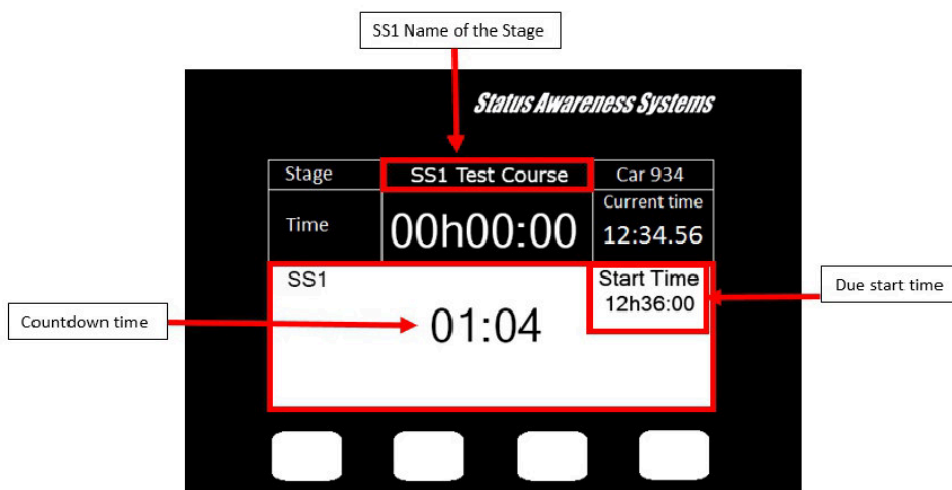

SCREEN 2. Countdown to Stage Start

SCREEN 3 – Once the start time is reached, the screen will turn green as shown below and the competitor has to proceed into stage.

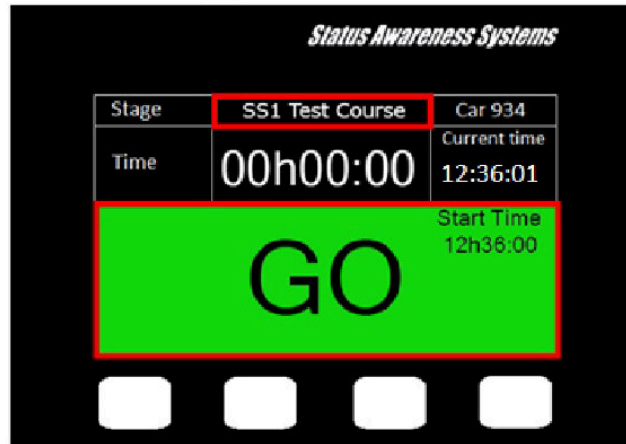

SCREEN 3. Stage Start

SCREEN 4 – Once the competitor has started the stage, the unit will automatically switch to on stage mode. The unit will start timing and the blue bar will appear on the left hand side of the screen.

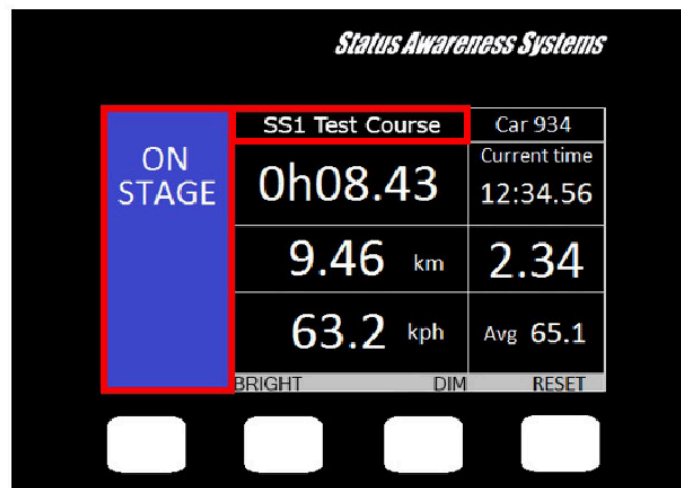

SCREEN 4. Stage mode

SCREEN 5 – If the start is postponed for whatever reason and the start time is cancelled, the unit will display the message "START TIME CANCELLED". Once it is clear to send cars again the official will re-issue a new start time.

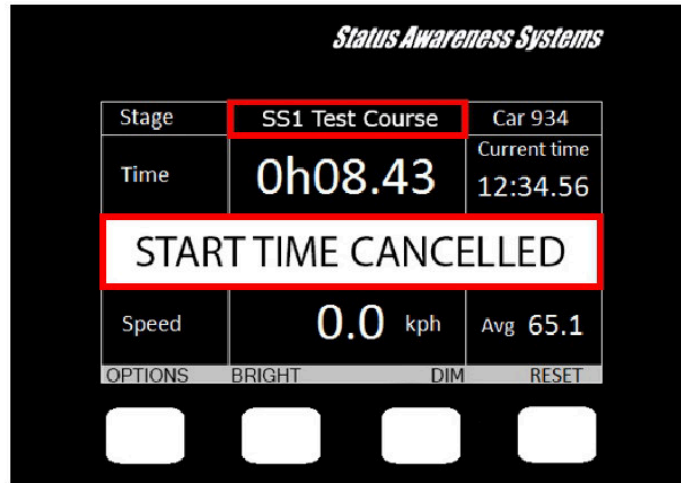

SCREEN 5. Start Time Cancelled

3. Hazard Alerts

The unit's primary function is to help alert race control of incidents on the course. The incident is notified to race control with different levels of hazard depending on the severity.

SCREEN 6 – If a car stops during a stage, the unit will automatically transmit a HAZARD notification; this can either be upgraded to OK or downgraded to SOS by pressing the corresponding button to the text. A timer counts up to 60 seconds as an indication to press the "OK".

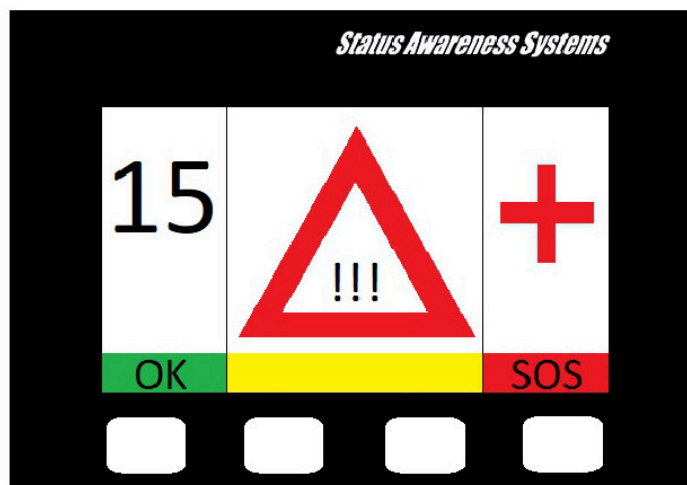

SCREEN 6. HAZARD Notification

SCREEN 7 – If you select OK after the HAZARD alert, then the following screen will appear, showing that you and the car are OK.

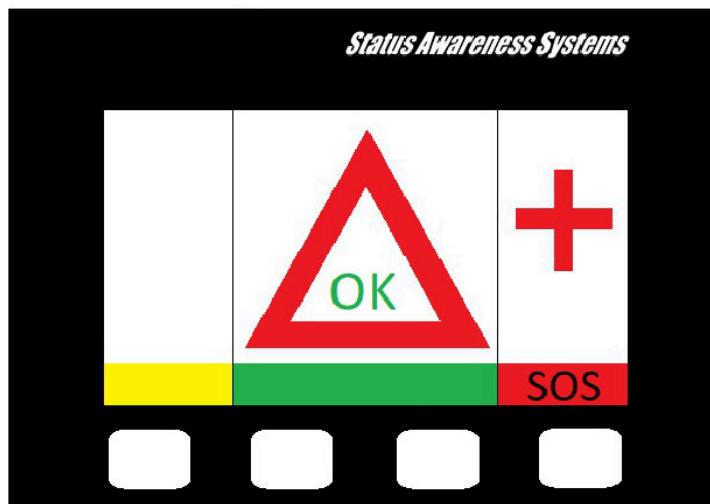

SCREEN 7. OK Acknowledgment

SCREEN 8 – If the manual SOS button is pressed, it must be confirmed as either a fire or medical SOS by pressing one of the two middle buttons. It can also be cancelled if pressed by mistake. If a car is involved in a High G impact, an automatic SOS message will display. If no urgent assistance is required, you can downgrade to OK by selecting the corresponding button.

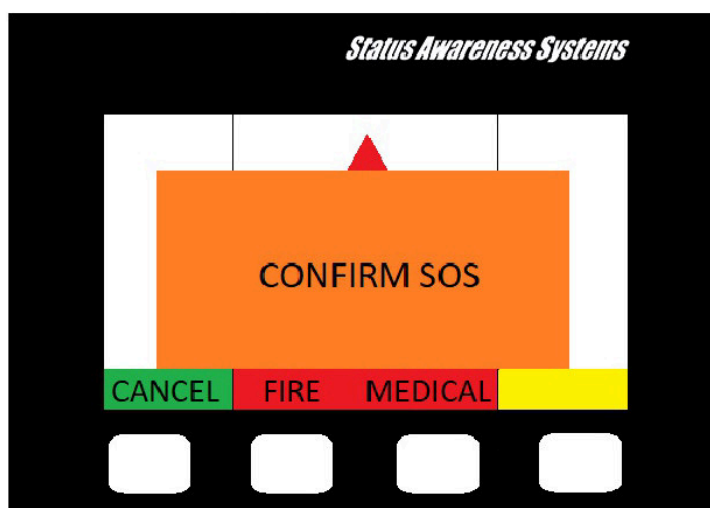

SCREEN 8. Confirm Fire SOS or Medical SOS

SCREEN 9 – When the SOS is confirmed, the screen 9 will display. Even once confirmed, the hazard can be changed to OK. Pressing OK will inform race control that the crew are OK and do not need medical assistance.

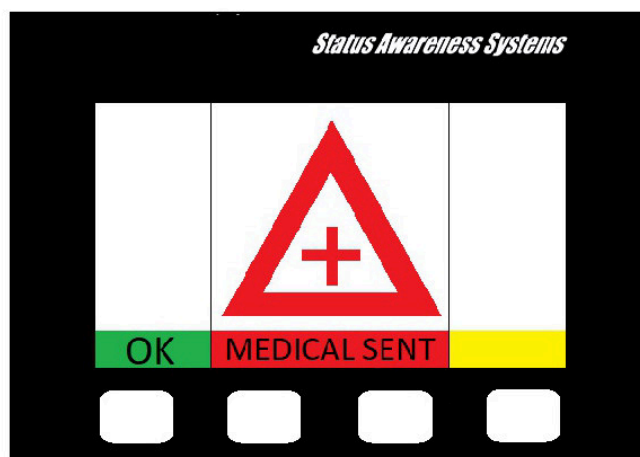

SCREEN 9. SOS Notification

4. Red Flag

SCREEN 10 – In the case of a serious incident, a stage may be red flagged from Race Control. The red flag will display a full screen warning until it is acknowledged. To acknowledge the flag the far left button must be pressed.



SCREEN 10. RED FLAG Acknowledge

SCREEN 11 – Once the red flag has been acknowledged, normal stage functions will display with a warning still at the top of the screen.

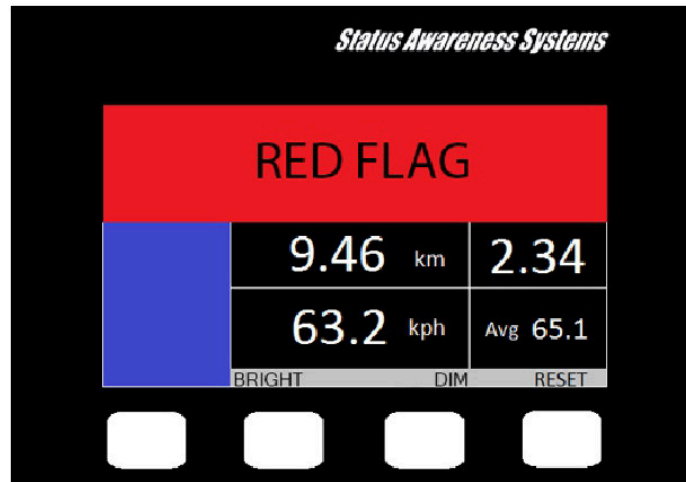

SCREEN 11. RED FLAG in Stage Mode

5. Transport Menu

SCREEN 12 – In transport mode, the unit has a menu that can be accessed by pressing the options button.

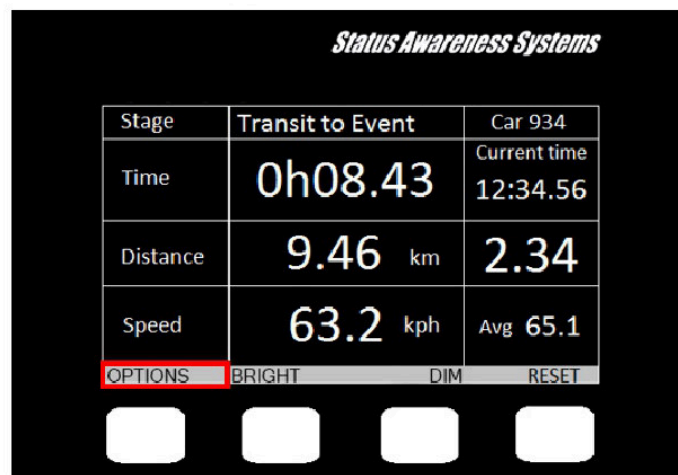

SCREEN 12. Transport Mode

SCREEN 13 – The option menu will allow the crew to view stage times “VIEW TIMES” or send a manual hazard/SOS “SEND HAZARD”.

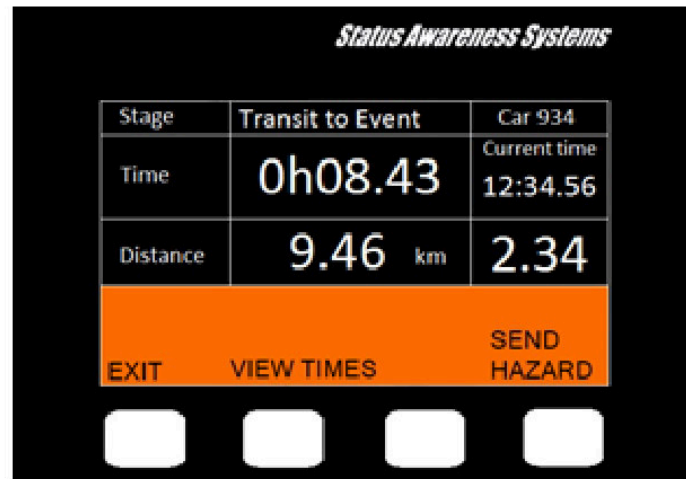

SCREEN 13. Transport Mode – View times/Send Hazard

5.1. Stage Times

SCREEN 14 – By pressing the “VIEW TIMES” button, provisional transit and competitive stage times will display. You can select times for any of the completed stages with the next and previous buttons.

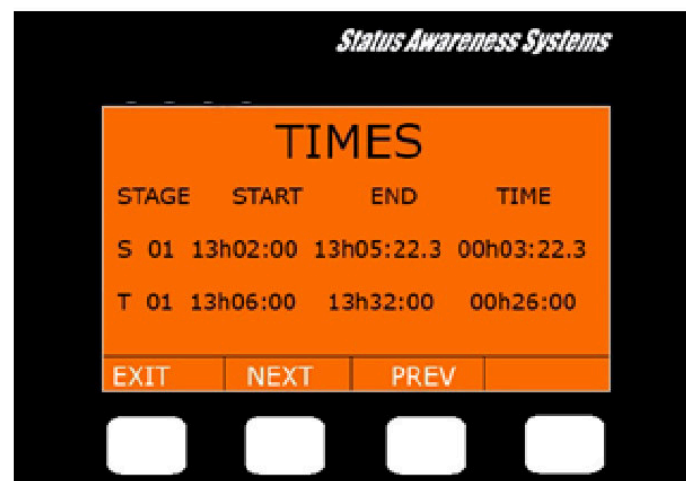

SCREEN 14. Times of completed stages

5.2. Manual Hazard

SCREEN 15 – If manual hazard is sent in transport mode, this can be upgraded or downgraded the same way as a stage hazard. If the hazard is no longer required, it can also be cancelled by pressing either of the two middle buttons “PRESS TO CANCEL”.

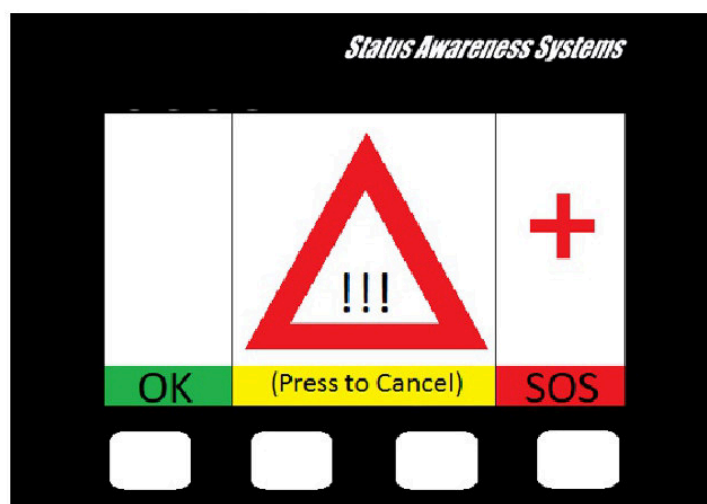

SCREEN 15. Manual Hazard in Transport Mode

6. Contact us

For assistance, please contact the RallySafe Support Team by emailing: info@statusas.com

Please be as descriptive as you can when describing the problem. It would help us if you provide the following information at a minimum:

- Name of event.
- Vehicle or feature affected.
- Stage of incident.
- Time of incident.
- Any additional details.

**Appendix 8:
START LIGHT SEQUENCE**

Start Procedure

Countdown:

30 seconds to GO – red zone and red light

10 seconds to GO – 1 (short) Beep + red zone and red light

5 seconds to GO – 1 (short) Beep every sec + yellow zone and yellow light flashing

“GO” Signal: Green light – Start Beep

After “GO” Signal: 20 seconds free start + green zone and green light



BEFLÜÜÜGELT DURCH DEN SOMMER.

MIT DEM GESCHMACK VON BEACH BREEZE.



NUR FÜR
KURZE ZEIT



Red Bull

BELEBT GEIST UND KÖRPER®