



SUPPLEMENTARY REGULATIONS

NAC Insurance / Hella International Rally of Whangarei 06-08 June 2008

2008 FIA Asia-Pacific Rally Championship for Drivers & Co-drivers
2008 FIA Asia-Pacific Rally Cup for Manufacturers
2008 FIA Pacific Cup
2008 FIA Asia-Pacific Rally Cup for Drivers, Co-Drivers and Manufacturers of
Group N 2WD 2 Litre Cars
2008 Vantage Aluminium Joinery New Zealand Rally Championship

Copies of the 2008 Rally General Prescriptions applying to all FIA Rally Championships and the FIA Asia-Pacific Rally Championship regulations are available on the FIA website:

<http://www.fia.com/sport/Regulations/rallyregs.html>

Rally Office Postal Address:

PO Box 62 021

Mt Wellington, 1641, Auckland, New Zealand

Telephone: +64-9-276-0882 Facsimile: +64-9-276-0881

Email: info@rallywhangarei.co.nz

www.rallywhangarei.co.nz

Rally Headquarters Address:

Wednesday 4 June – Sunday 8 June 2008

Cnr Dent Street & Quayside Way, Whangarei

Telephone: TBA Facsimile: TBA

Email: info@rallywhangarei.co.nz

www.rallywhangarei.co.nz

Supplementary Regulations

Announcement

The rally will be run in compliance with the International Sporting Code (and its appendices), the General Prescriptions applicable to all FIA Rally Championships, the regulations for the 2008 FIA Asia-Pacific Rally Championship, MotorSport New Zealand National Sporting Code which complies with the FIA regulations, 2008 New Zealand Rally Championship Portfolio and these Supplementary Regulations.

Modifications, amendments and / or changes to these Supplementary Regulations will be announced only by numbered and dated bulletins (issued by the organisers or the stewards).

Additional information to specific articles in these Supplementary Regulations will be published in Rally Guide 2 (RG2) issued on Friday 16 May 2008.

1.	Programme of the Rally	3
2.	Organisation & Description	4
3.	Entries	6
4.	Insurance	8
5.	Advertising & Identification	9
6.	Tyres	9
7.	Fuel	9
8.	Reconnaissance	9
9.	Administrative Checks	11
10.	Scrutineering, Sealing and Marking	11
11.	Features of the Rally	12
12.	Safety Cars	14
13.	Prizes	14
14.	Final Scrutineering & Protests	15
	Appendix 1 – Itinerary	16
	Appendix 2 – Names and photographs of CROs	18
	Appendix 3 – Competition numbers and advertising	19

For information on radio use and New Zealand vehicle registration
please refer to the Rally Guide

Official Noticeboard: Rally Headquarters
Wednesday 4 June 0900hrs to Sunday 8 June 1900hrs

A copy of all items on the official noticeboard will be on the official website
www.rallywhangarei.co.nz in the Noticeboard section.

1. Programme

Friday 21 March		
0900hrs	Entries Open	Permanent Secretariat
Friday 16 May		
0900hrs	Rally Guide 2, Road Books and Maps published	Permanent Secretariat
1700hrs	Entries Close	Permanent Secretariat
	Closing Date for Co-driver details	Permanent Secretariat
Friday 23 May		
0900hrs	Publication of list of entries in seeded order	Permanent Secretariat
Wednesday 28 May		
0900hrs	Media Accreditation Closes	Permanent Secretariat
1700hrs	Last day for Service Park and Scrutineering Requirements	Permanent Secretariat
Tuesday 3 June		
1700hrs	Scrutineering Schedule published on website in 'Noticeboard' section	Official Noticeboard
Wednesday 4 June		
0900-1800hrs	Administrative Checking & Reconnaissance Registration commences	Secretariat
Thursday 5 June		
0800-1800hrs	Reconnaissance – Day 1	
0900-1700hrs	Media Centre open	Rally HQ
1700-2100hrs	Pre-Event Scrutineering (all cars as per published schedule)	VTNZ, 119 Port Rd, Whangarei
Friday 6 June		
0800hrs	Service Park Opens	Quayside Town Basin
0800-1900hrs	Media Centre open	Rally HQ
0900-1100hrs	Shakedown, APRC Registered competitors and invited others	Pohe Island, Whangarei
1100hrs	Closing of Club & Manufacturers' Team Entries	Secretariat
1115-1145hrs	Reconnaissance – Day 2	
1400hrs	FIA Pre-Event Press Conference	Media Centre
1500hrs	First Stewards' Meeting	Rally HQ
1530-1630hrs	Pre-start Park will be open	Cameron Street Mall
1600hrs	Publication of start list for Ceremonial Start & Day 1	Official Noticeboard
1600-1700hrs	Driver Autograph Session	The Cameron Street Mall, Whangarei City
1700hrs	Opening Ceremony	The Cameron Street Mall, Whangarei City
1800hrs	First APRC Car over Ramp	The Cameron Street Mall, Whangarei City
Saturday 7 June		
0700-1900hrs	Media Centre open	Rally HQ
0800hrs	Start Day 1	Quayside Town Basin
1730hrs	Arrive Parc Ferme In	Quayside Town Basin
2100hrs	Publication of start list for Day 2	Official Noticeboard
Sunday 8 June		
0700-1900hrs	Media Centre open	Rally HQ
0730hrs	Start Day 2	Quayside Town Basin
1500hrs	Ceremonial Finish & Prizegiving	Quayside Town Basin
1530hrs	Final Scrutineering	Pacific Ford, Cnr Dent and Carruth Streets, Whangarei
1530hrs	FIA Post Event Press Conference	Media Centre
	Top 3 APRC registered competitors	
	Driver & Co-Driver of 1 st , 2 nd & 3 rd overall	
	1 st New Zealander	
	1 st , 2 nd and 3 rd New Zealand Rally Championship Driver & Co-Driver	
1800hrs	Provisional Final Classification published	Official Noticeboard
1830hrs	Final Official Classification published	Official Noticeboard
1900hrs	Rally Headquarters Closes	

2. Organisation and Description

2.1 FIA titles for which the rally counts

- 2008 FIA Asia-Pacific Rally Championship for Drivers and Co-Drivers
- 2008 FIA Asia-Pacific Rally Cup for Manufacturers
- 2008 FIA Pacific Cup
- 2008 FIA Asia-Pacific Rally Cup for Drivers, Co-Drivers and Manufacturers of 2WD 2 Litre Cars

Other Titles:

- 2008 Vantage Aluminium Joinery New Zealand Rally Championship

2.2 Visa Numbers – FIA and ASN

FIA visa No: 3APRC/250208 Issued on: 25/02/2008
ASN visa No: 5925 Int
5926 Nat

2.3 Organiser's Name

Name of the organising club: Rally New Zealand
Name of the National Sporting Authority: MotorSport New Zealand Inc.

2.4 Address and Contact Details

Postal Address: NAC Insurance / Hella International Rally of Whangarei
PO Box 62-021, Mt Wellington 1641
Auckland, New Zealand

Courier Address: C/o Northern Sports Car Club
Mt Richmond Domain
1110 Great South Road, Otahuhu
Auckland, New Zealand

Phone: +64-9-276 0882
Fax: +64-9-276 0881
Email: info@rallywhangarei.co.nz
Website: www.rallywhangarei.co.nz

2.5 Organisation Committee

Committee of Honour: Mr Jarrard Ahlers, NAC Insurance
Mr Ian Brahne, Hella New Zealand
Mr Stewart McElwain, Enterprise Northland
Mr Chris Rickards, Subaru of New Zealand
Mr Stan Semenov, Mayor of Whangarei
Ms Jude Thompson, Enterprise Northland
Mr Neil Tiller, Mayor of Kaipara

Executive Committee

Laurie Brensell (Chairman), Chris Carr, Steve Foster, Casey Graham, Lara Herbert, Paul Mallard, Willard Martin, Peter Nelson.

Event Committee:

Laurie Brensell (Chairman)			
Andy Adams	Stuart Barnett	Andrea Bourhill	Margaret Brensell
Cherie Brown	Dr Roger Brown	John Bruce	Chris Carr
Brian Dale	Toni Davis	Jo-Anne Eyre	Joelle Eyre
Carl Fenn	Didier Ferreol	Steve Foster	Kevin Gahan
Richard Gamble	Kate Gordon	Casey Graham	Chris Grant
Rob Hall	Dave Hargreaves	Lara Herbert	John Holland
Heather Holland	Ron Jackways	Mark Jackways	Keith Jeffery
Andrew Jenkin	Adam Johnston	Peter Johnston	Grahame Knight
David Karrasch	Paul Kendrick	Steve Lachman	Gary Lathrope
Malcolm Laycock	Brian Littlewood	Brenda Lupton	Stu Macaskill
Logan McLean	Gary Maitland	Neil Mallard	Paul Mallard
Tony Mannering	Willard Martin	Graham Mortensen	Murray O'Donnell
Greg Paul	Bryce Platt	Dave Robb	Campbell Robertson
Sel Sapwell	Brian Stubbs	Karen Stubbs	Paul Te Punga
Phil Teal	Peter Thomson	Fiona Whyte	Allan Windsor
Bob Young			

2.6 Stewards of the Meeting

Chairman	Mr Garry Connelly	FIA
	Mr Zayn Khan	FIA
	Mr Wayne Scott	MotorSport NZ
Secretary to the Stewards	Mrs Margaret Brensell	

2.7 FIA Observers and Delegates

Observer	Mr Peter Macneall
Technical Delegate	Mr Julian Leach

2.8 Senior Officials

Clerk of the Course	Mr Steve Foster
Deputy Clerk of the Course	Mr Willard Martin
Assistant Clerks of the Course	Mr Stuart Barnett
	Mr Laurie Brensell
	Ms Joelle Eyre
	Mr Casey Graham
	Ms Lara Herbert
	Mr Neil Mallard
Chief Scrutineer	Mr Dave Robb
Motorsport NZ Technical Officers	Mr Rex Clark
	Mr Kevin Dwyer
	Mr Mike Clements
	Mr Mark Sheehan
	Mr Justin Scelly
Competitor Relations Officers	Mr Gary Lathrope
	Mr Graham Mortensen
Chief Safety Officer	Mr Malcolm Laycock
Chief Medical Officer	Dr Roger Brown
Chief Timing Marshal	Mr John Holland
Media	Ms Kate Gordon

Communications Chiefs	Mr Richard Gamble Mr Brian Littlewood
Service Park Co-ordinators	Mr Tony Mannering Mr Phil Teal
Results Co-ordinator	Mr Chris Grant
Police Liaison Officer	Snr Sgt Alistair Ward
Secretary of the Event	Mr Paul Mallard
Judges of Fact (Compliance)	All Named Officials

2.9 Road Surface

Gravel

2.10 Rally Headquarters Location

Cnr Dent Street & Quayside Way, Whangarei

Telephone: TBA

Facsimile: TBA

Email: info@rallywhangarei.co.nz

Website: www.rallywhangarei.co.nz

2.11 Location of Overnight and Finish Parc Fermé:

Quayside Town Basin, Whangarei

3. Entries

3.1 Entry Procedure

The entry application will only be accepted on the official entry form accompanied by the total entry fees or a receipt issued by the Competitor's National Sporting Authority.

3.2 Number of Entrants Accepted and Classes

The maximum number of entries is 90. If more than 90 entries are received the organisers reserve the right to extend this number and to decide which entries (among the non-priority drivers) will be accepted.

Entries will be accepted from Group A and Group N cars whose homologations have expired up to a maximum of four years before the beginning of the current year in accordance with Article 5 of the 2008 FIA Asia Pacific Rally Championship Regulations.

Production Cars (Group N)

Cylinder capacity classes:

Class N1: FIA Group N up to and including 1400cc

Class N2: FIA Group N over 1400cc up to and including 1600cc

Class N3: FIA Group N over 1600cc up to and including 2000cc

Class N4: FIA Group N over 2000cc

Touring Cars (Group A) excluding World Rally Cars and A8 cars

Cylinder capacity classes:

Class A5: FIA Group A up to and including 1400cc

Class A6: FIA Group A over 1400cc up to and including 1600cc

Class A7: FIA Group A over 1600cc up to and including 2000cc

2 Litre, 2WD Cars

Complying with the provisions of the FIA Asia Pacific Rally Championship regulations.

Super 1600 cars

Super 2000 cars

Homologated Kit cars between 1400cc to 1600cc complying with Article 255 – 6.2 “Weight” of Appendix J.

Two-wheel drive cars equipped with a supercharged diesel engine with a nominal cylinder capacity of less than 2000cc are accepted in Groups A and N.

3.3 Entry Fees and Packages for all groups of Competitors

3.3.1 Competitors Registered to contest the 2008 FIA Asia Pacific Rally Championship and Pacific Cup:

- With optional advertising proposed by Organisers:
NZ\$3,500.00
- Without optional advertising proposed by Organisers:
NZ\$4,500.00

3.3.2 Entry fee for Competitors who are not registered to contest the 2008 FIA Asia Pacific Rally Championship and Pacific Cup:

- With optional advertising proposed by Organisers:
NZ\$2,500.00
- Without optional advertising proposed by Organisers:
NZ\$3,500.00

3.3.3 The entry fees specified in 3.3.1 and 3.3.2 include:

- One set of Road Books
- Two Rally Guide 2
- Two Competitor ID Passes
- One Team Manager ID Pass
- Four 2 Day Spectator Event Passes
- Two Route Maps
- Vehicle Livery Pack
- Two Service Vehicle Plates
- Reconnaissance Material

3.3.4 Additional fees

- | | |
|------------------------------------|------------|
| • Manufacturer’s Team Award | NZ\$200.00 |
| • Club Team Award | NZ\$150.00 |
| • Change of Crew Member | NZ\$50.00 |
| • Additional Service Vehicle Plate | NZ\$100.00 |
| • Stage Notes | NZ\$270.00 |

3.4 Payment Details

Payment of entry fees can be made by;
Personal Cheque, Bank Draft, Telegraphic Transfer, or
Credit Card:- Visa/Amex/Diners/MasterCard

Bank account details for sending a Telegraphic Transfer are:

Bank:	ASB Bank Ltd
Address	Corner Queen Street & Wellesley Street Auckland New Zealand
Account Name:	Rally of New Zealand
Account Number:	12-3011-0203851-00
IBAN/Swift code:	ASBBNZ2A

Please use the driver's surname as a reference when making the payment. When paying by Telegraphic Transfer it is essential that you provide details of this payment by fax to the Rally Office to ensure that payment is receipted prior to the close of entries.

Note: *All charges incurred by the bank must be charged to the sender. A 3% surcharge will apply to credit card transactions.*

The Entry Fee must be received in full by the organisers within 2 days of the close of entries. If the Entry Form is sent by fax or email the original must reach the organisers within 7 days following the closing date of entries.

3.5 Refunds

Entry Fees will be refunded in full only:

- (a) To candidates whose entry has not been accepted.
- (b) In the case of the rally not taking place.

No other refunds will be made.

4. Insurance

All New Zealand residents and overseas visitors to New Zealand are covered by 24hour no-fault personal injury caused by an accident, where that accident is deemed to be an accident as defined in the "Injury Prevention, Rehabilitation and Compensation Act 2001".

Overseas visitors are recommended to have personal travel and medical insurance.

Third Party Property Insurance or Comprehensive Vehicle Insurance is the responsibility of the entrant/competitor.

Service vehicles, management vehicles and reconnaissance vehicles, including those bearing special plates issued by the organisers may never be considered as official participants in the rally. They are therefore not covered by the insurance policy of the rally and will remain the sole responsibility of their owner.

Competitors and crew members are covered for public liability under a master policy held by MotorSport New Zealand for an amount of up to **NZ\$10 million** for the entire event. Full details may be obtained upon request to the organisers.

In the event of an accident the competitor or his/her representative must notify the Clerk of the Course in writing within 4 hours. He/She must provide full details including the names and addresses of those involved and any witnesses.

5. Advertising and Identification

5.1 Restrictions

Tobacco advertising in New Zealand is prohibited except by special exemption on individual application.

5.2 The Organiser's Advertising – See Appendix 3

Competition numbers, rally plates and advertising shall be affixed on the car before scrutineering. Space for the organiser's advertising must be reserved on the car, unless the higher entry fee as per 3.3.1 or 3.3.2 has been paid.

5.3 Rally Plates and Competition Numbers will be provided by the Organisers and must be affixed as specified in accordance with Appendix 3 of these supplementary regulations.

5.4 Service plates shall be placed on the outside of the windscreen in the top left hand corner.

6. Tyres

6.1 The use of studded or spiked tyres is prohibited under pain of exclusion. Refer also to Appendix IV of the 2008 FIA Rally Championship General Prescriptions.

7. Fuel

Fuel shall comply with the provisions of Article 9 of Appendix J Article 252 of the FIA International Sporting Code.

7.1 The use of complying FIA type fuels is permitted.

7.2 The use of unleaded commercial petrol available at petrol filling stations is permitted. Filling stations at Whangarei only deliver unleaded premium 95 and diesel.

7.3 Distribution during the rally:

Refuel Zones (RZ) will be established as follows –

- Pacific Ford immediately after the Service Park
- "MOBIL" station at Whangarei

Plus supplementary RZ –

- Day 1 at the "GAS" station at Paparoa
- Day 2 at the junction of Paparoa Oakleigh and Millbrook Roads.

Note: All Competitors will need to make their own supply arrangements.

Full details will be shown in the Road Book.

8. Reconnaissance

8.1 Procedure for Registration

Before starting reconnaissance all crews must supply the Organisers with full details of the reconnaissance car. Reconnaissance registration will take place as follows:

Place: Rally HQ, Cnr Dent Street & Quayside Way, Whangarei

Time: Wednesday 4 June from 0900 to 1800 hrs.

Those competitors who wish to complete Administrative Checks and Reconnaissance Registration before the event may do so by prior appointment at the Rally New Zealand Office in Auckland or at the Event Secretariat.

8.2 Schedule

Reconnaissance must be carried out in accordance with the Reconnaissance Schedule below.

RECONNAISSANCE SCHEDULE

THURSDAY 5 JUNE			
SS NO.	SS NAME	PASS	REPORT TIME
9 / 13	Brooks	1 st Pass	0800 to 0815hrs
10 / 14	Millbrook	1 st Pass	0845 to 0900hrs
11 / 15	Waipu Caves	1 st Pass	0930 to 0945hrs
9 / 13	Brooks	2 nd Pass	1045 to 1100hrs
10 / 14	Millbrook	2 nd Pass	1130 to 1145hrs
11 / 15	Waipu Caves	2 nd Pass	1215 to 1230hrs
1 / 5	Wairere	2 Passes in a loop	1330 to 1345hrs
2 / 6 & 3 / 7	Bull & Cassidy	1 st Pass	1430 to 1445hrs
2 / 6 & 3 / 7	Bull & Cassidy	2 nd Pass	1600 to 1615hrs
FRIDAY 6 JUNE			
SS NO.	SS NAME	PASS	REPORT TIME
4 / 8 / 12	Super Special	2 Passes in a loop	1115 to 1130 hrs

8.3 Specific Restrictions – Speed Limit

The regulations for reconnaissance apply for all drivers.

8.3.1 Reconnaissance will be conducted in convoy strictly in accordance with the published schedule. No late entry into a stage for reconnaissance will be permitted. During special stages crews must remain within the convoy.

8.3.2 Reconnaissance outside the schedule as set by the organisers is considered a very serious offence and will be advised to the Stewards who may apply penalties.

8.3.3 At all times competitors' maximum speed on Special Stages will be 80kph.

8.3.4 All cars must have their headlights on at all times whilst travelling on the roads of the special stages.

8.3.5 Crews are permitted to enter a special stage only from the start point shown in the Road Book and may not under any circumstance drive in a direction opposite to that of the rally, unless instructed by an official of the event.

8.3.6 Crews must stop at the start of each stage where a Rally Official will endorse the crew's Reconnaissance Pass Card and at any other location where instructed.

8.3.7 Competitors shall create their own safety plan which appoints a team member who shall be responsible for the well being of the crew during the reconnaissance period.

- 8.4** Each crew using a reconnaissance car will be issued with 3 x Number Sets. The two large sets of numbers must be placed on the rear side windows of the reconnaissance vehicle. The small numbers must be placed on the front windscreen in the top corner on the co-driver's side. Each crew will be issued with a Reconnaissance Pass Card valid for up to two passages in convoy over each special stage according to the reconnaissance time schedule.
- 8.5** Tyres used in reconnaissance must be designed primarily for use on tarmac roads. They must not exceed a tread depth of 8.5mm. Straight circumferential grooves may be no wider than 10mm, all other grooves at any angle to the circumference may be no wider than 7mm. Competitors are permitted to use tyres remoulded on competition casings with tread patterns complying with the above.

9. Administrative Checks

- 9.1 Place:** Rally HQ, Cnr Dent Street & Quayside Way, Whangarei
Time: Wednesday 4 June from 0900 till 1800hrs.

Those competitors who wish to complete Administrative Checks before the event may do so by prior appointment at the Rally New Zealand Office in Auckland or at the Event Secretariat.

9.2 Documents to be Presented

The following items will be checked at Administrative Checks:

- Entrant Licence
- Driver and Co-driver competition licence
- Driver and Co-driver civil driving licence
- ASN stamp/visa for foreign competitors
- MotorSport New Zealand affiliated car club membership (NZ entrants only)
- Vehicle Log Book (NZ entrants only)
- Completion of all details on the entry form

Competitors are required to hold a signed Administrative Clearance Form prior to Scrutineering.

10. Scrutineering, Sealing and Marking

Competitors must present a signed Administrative Clearance Form prior to Scrutineering. Competition numbers, rally plates and advertising decals shall be affixed on the car before entering the Scrutineering venue.

10.1 Programme of Scrutineering

- Place:** VTNZ 119 Port Road Whangarei
Time: Thursday 5 June - Report Times from 1700 till 2100 hrs.

10.2 Election of Preferred Times

The scrutineering schedule will be posted on the website (in the 'Noticeboard' section) on Tuesday 3 June at 1700hrs. Competitors who wish to be allocated a scrutineering time in conjunction with another competitor or at a certain time period must advise the secretariat by Wednesday 28 May.

10.3 Mud Flaps

Must be fitted in compliance with Appendix J, Article 252-7.7

10.4 Windows

The fitment of anti-shatter film (transparent or tinted but not silvered) on the side windows is mandatory. The thickness of these films must not be greater than 100 microns. Where tinted film is used the visible light transmittance (VLT) must not be reduced below 35%. Refer Appendix J, Article 253-11.

10.5 Marking and Sealing

The FIA Scrutineers will seal/mark all cars contesting the FIA APRC Championship. Other cars will be sealed/marked at the discretion of the organisers.

11. Features of the Rally

11.1 Opening Ceremony Procedure

The Opening Ceremony is compulsory for all competing cars and crews and will take place as follows:

Place: The Cameron Street Mall, Whangarei City

Time: Friday 6 June at 1800hrs

The Opening Ceremony will be preceded by a pre-start park, adjacent to the start zone. A representative of the team may deliver the car to the pre-start park. The pre-start park will be open from 1530 to 1630 hrs. The penalty for late arrival is NZ\$20 per minute.

11.1.1 Crews must wear their approved overalls and be present with the car in the pre-start park at least 15 minutes before the crew's due start time.

11.1.2 Between 1600hrs and 1700 hrs APRC Registered and NZRC registered drivers will be required for promotional purposes in accordance with a schedule that will be published in RG2.

11.1.3 Cars will start in reverse event seeded order after the Clubman's Rally at approximately 30 second intervals.

11.1.4 No Time Cards will be issued.

11.2 Starting Intervals and Start Order

The starting order for all days is established as follows:

1. FIA seedings
2. APRC eligible competitors
3. All other competitors

The starting interval for cars whose drivers have FIA seedings plus at least the next 5 crews will be a minimum of 2 minutes for the first Day. The same number of crews will take the start of the second Day at intervals of at least a minimum of 2 minutes.

All other cars will be at a minimum of one minute for all Days.

11.3 Time Card Change during the Rally

Time cards will be issued at the following Time Controls:
TC0 TC4A TC8D TC12A

11.4 Starting System of Special Stages

On Special Stages the start will be by lights under the following sequence.

Red light shows until 10 seconds before Start.

At 10 seconds the Red and Amber lights show.

At 5 seconds the Red light goes out while Amber lights count down the last 5 seconds.

The Green light shows at 0 seconds and for 6 seconds afterwards.

There is also a digital display clock for competitors.

A false start will be detected by a photocell placed 40 cm in front of the starting line.

11.5 Official Time

Official time throughout the entire rally will be set from the Industrial Research Ltd Talking Clock: Telephone 0900 45678

11.6 Identification of Officials:

The post chiefs and other officials will be identified as follows:

Post Chief	Green Vest with black POST CHIEF
Other Post Officials	Green Vest with black CONTROL
Medical Officers	Yellow Vests
Safety Marshals	Orange Vest with black SAFETY
Competitor Relations Officers	Orange Vest with black COMPETITOR RELATIONS

11.7 Time Controls/Check In Procedure

If two or more crews check in on the same minute at a Time Control immediately prior to the start of a Special Stage, their provisional start times for that Special Stage shall be in the order of their due arrival times at the preceding Time Control. If the arrival times at the preceding Time Control are the same, then the times at the Time Control previous to that will be taken into account and so on.

11.8 Early Check In at the End of a Day

It is permissible to check in early at TC15B without incurring any penalty.

11.9 Notification of Traffic Offence Notice & Accident Reporting

Competitors are required, upon entering all Parc Fermés to notify the Competitor Relations Officer in writing if they or any member of their team have received a Traffic Offence Notice. The submission of an entry is also an agreement that the New Zealand Police may advise the organisers of the details of any notices issued.

11.10 Retirement

Any crew retiring permanently from the rally must report such retirement to the organisers as soon as possible. Please ring the organisers using the telephone number in the road book and confirm using the "withdrawal form" at the back of the

road book. Any crew failing to comply will be liable to a sanction at the Stewards' discretion.

11.11 Finish Procedure and Finish of the Rally

The Finish of the rally will be at TC 15C. From there, competitors must follow officials' instructions to drive over the finish ramp and into final parc fermé.

The Top 3 registered drivers in the APRC will cross the finish ramp first in the following order:–

3rd placed car onto ramp, interview and park as directed by officials.

2nd placed car onto ramp, interview and park as directed by officials.

The winning car after receiving the winner's awards will remain on the ramp for photo session.

The 3 winning crews will then proceed to the awards ceremony podium at the base of the ramp for presentation of trophies, national anthems & flag raising, champagne shower & photo shoot.

The Top 3 NZRC finishers will then perform the same procedure as the Top 3 registered drivers in the APRC, followed by the remainder of the field in finishing order.

11.12 Removal of Cars from the Final Parc Fermé

All cars must be removed from the final Parc Fermé at the latest by 2000hrs on Sunday 8 June, providing the Stewards have authorised the Parc Fermé to be opened.

12. Safety Cars

Safety Cars (Gravel Cars) are not permitted on this event.

13. Prizes

All trophy awards will be made on the Finish Ramp.

13.1 Prizes

13.1.1 General Classification

1st Trophies for Driver and Co-driver

2nd Trophies for Driver and Co-driver

3rd Trophies for Driver and Co-driver

Trophies will also be awarded to each Driver and Co-driver placed 1st, 2nd and 3rd in each class.

13.1.2 FIA Asia Pacific Rally Championship

1st Trophies for Driver and Co-driver

2nd Trophies for Driver and Co-driver

3rd Trophies for Driver and Co-driver

1st Trophy for FIA Pacific Cup winner

13.1.3 New Zealand Rally Championship

As per the NZRC Portfolio

13.1.4 Other Awards

Manufacturer's Team: 1st Trophy

Club Team: 1st Club Team Trophy, plus trophy for each member.

- a) Entries for the Teams awards shall be accepted until 1100 hrs Friday 6 June 2008.
- b) Each team shall consist of at least 3 but no more than 5 cars.
- c) For the Manufacturer's Award, each vehicle must be of the same make but not necessarily of the same model or type.
- d) For the Club Team Award all drivers must be current members of the club which must be affiliated to a national ASN.
- e) Each Manufacturer or Club may enter more than one team for the respective award, but for each award the same crew may be part of only one team.
- f) The winning team shall be the one whose three highest placed cars have the lowest combined total time for the rally.
- g) The Manufacturer's Trophy and the Club Team Trophy shall not be awarded unless a minimum of two teams start in each.

14. Final Scrutineering and Protests

14.1 Final Scrutineering

Place: Pacific Ford, Corner Dent & Carruth Streets, Whangarei

Time: Sunday 8 June at 1530 hrs.

A summons to attend the final scrutineering will be given to the competitors chosen by the Stewards. The cars will be collected from the Pick Up area after the Ceremonial Finish and taken to scrutineering by the driver or a team representative duly designated in writing, accompanied by a representative of the organisers. A sufficient number of mechanics with tools must follow each chosen car, should the scrutineers wish to dismantle the car.

14.2 Protest Fees

The protest fee set by the FIA is EUR€500.00.

If the protest requires the dismantling and the reassembly of different parts of a car, the claimant must pay an additional deposit of NZ\$1,000.00.

Refer to the FIA Rally Championship General Prescriptions, Article XXIV Protests and Appeals.

14.3 Appeal Fees

- (a) Sum for a National Appeal Fee (ASN) NZ\$5,000.00.
- (b) Sum for an International Appeal Fee (FIA) EUR€6,000.00.

Appendix 1 - ITINERARY

The Itinerary as published in the Road Book will be the definitive itinerary.

V3 - 20.02.08						
CEREMONIAL START - FRIDAY 06 JUNE 2008						
TC	Location	SS	Liaison	Total	Target	1st Car
SS		Dist.	Dist.	Dist.	Time	Due
	The Cameron St Mall. Whangarei City					17:30
START DAY 1 - SATURDAY 07 JUNE 2008						
TC	Location	SS	Liaison	Total	Target	1st Car
SS		Dist.	Dist.	Dist.	Time	Due
0	Start Day One - Quayside Town Basin					8:00
	Refuel: Pacific Ford	RZ 1				
	Km to next refuel	18.92	80.80	99.72		
1			73.15	73.15	1:15	9:15
SS 1	Wairere 1	18.92				9:18
	Refuel: "GAS" Paparoa	RZ 2				
	Km to next refuel	60.64	35.80	96.44		
2			7.65	26.57	0:40	9:58
SS 2	Bull 1	35.97				10:01
3			0.43	36.40	0:45	10:46
SS 3	Cassidy 1	23.17				10:49
4			33.29	56.46	0:55	11:44
SS 4	Whangarei Super Special 1	1.50				11:47
4A	Regroup and Technical Zone In		2.08	3.58	0:10	11:57
4B	Regroup Exit / Flexi Service A In					
	Flexi Service A (Quayside Town Basin)	79.56	116.60	196.16	0:20	
4C	Flexi Service A Exit / Regroup In					
4D	Regroup Exit					12:45
	Refuel: Pacific Ford	RZ 3				
	Km to next refuel	18.92	80.80	99.72		
5			73.15	73.15	1:15	14:00
SS 5	Wairere 2	18.92				14:03
	Refuel: "GAS" Paparoa	RZ 4				
	Km to next refuel	60.64	35.80	96.44		
6			7.65	26.57	0:40	14:43
SS 6	Bull 2	35.97				14:46
7			0.43	36.40	0:45	15:31
SS 7	Cassidy 2	23.17				15:34
8			33.29	56.46	0:55	16:29
SS 8	Whangarei Super Special 2	1.50				16:32
8A	Parc Ferme and Technical Zone In		2.08	3.58	0:10	16:42
8B	Parc Ferme Exit / Flexi Service B In					
	Flexi Service B (Quayside Town Basin)	79.56	116.60	196.16	0:45	
8C	Flexi Service B Exit / Overnight Parc Ferme In (Quayside Town Basin)					
	<i>For all classified cars TC 8C closes at</i>					20:00
	Day 1, section 1 + 2 totals	159.12	233.20	392.32		

SECTION 1

SECTION 2

Appendix 1 - ITINERARY

The Itinerary as published in the Road Book will be the definitive itinerary.

V3 - 20.02.08						
START DAY 2 - SUNDAY 08 JUNE 2008						
TC	Location	SS	Liaison	Total	Target	1st Car
SS		Dist.	Dist.	Dist.	Time	Due
8D	Parc Ferme Exit / Flexi Service C In					7:30
Flexi Service C (Quayside Town Basin)					0:20	
8E	Flexi Service C Exit / Regroup In					
8F	Regroup Exit					8:15
Refuel: Pacific Ford		RZ 5				
Km to next refuel		16.15	49.58	65.73		
9			42.11	42.11	0:45	9:00
SS 9	Brooks 1	16.15				9:03
Refuel: start SS10 Millbrook 1		RZ 6				
Km to next refuel		33.20	41.03	74.23		
10			7.47	23.62	0:27	9:30
SS 10	Millbrook 1	10.51				9:33
11			8.52	19.03	0:20	9:53
SS11	Waipu Caves 1	21.19				9:56
12			30.43	51.62	0:50	10:46
SS12	Whangarei Super Special 3	1.50				10:49
12A	Regroup and Technical Zone In		2.08	3.58	0:10	10:59
12B	Regroup Exit / Flexi Service D In					
Flexi Service D (Quayside Town Basin)		49.35	90.61	139.96	0:20	
12C	Flexi Service D Exit / Regroup In					
12D	Regroup Exit					11:43
Refuel: Pacific Ford		RZ 7				
Km to next refuel		16.15	49.58	65.73		
13			42.11	42.11	0:45	12:28
SS 13	Brooks 2	16.15				12:31
Refuel: start SS14 Millbrook 2		RZ 8				
Km to finish		31.70	38.28	69.98		
14			7.47	23.62	0:27	12:58
SS 14	Millbrook 2	10.51				13:01
15			8.52	19.03	0:20	13:21
SS15	Waipu Caves 2	21.19				13:24
15A	Service E In		29.76	50.95	0:50	14:14
Service E (Quayside Town Basin)		47.85	87.86	135.71	0:20	
15B	Service E Exit / Regroup In					14:34
15C	Regroup Exit					14:55
	Finish (Quayside Town Basin)					15:00
	Parc Ferme In (Quayside Town Basin)					
Day 2, section 3 + 4 totals		97.20	178.47	275.67		
DAY 1 totals		159.12	233.20	392.32		
DAY 2 totals		97.20	178.47	275.67		
		256.32	411.67	667.99		

SECTION 3

SECTION 4

Appendix 2 – Names and Photographs of CROs



CRO Hours of Operation and Location

Date	Location	Time
Thursday 5 June	Scrutineering	1700 – 2100 hrs
Friday 6 June	Rally HQ Secretariat	1500 – 1700 hrs
	Rally Start Cameron Street Mall	1700 – 1930 hrs
Saturday 7 June	Service Park Quayside Town Basin	0745 – 1700 hrs
Sunday 8 June	Service Park Quayside Town Basin	0645 – 1600 hrs
	Rally HQ Secretariat	1600 – 1830 hrs

Appendix 3 – Competition Numbers and Advertising

Rally Plates and Competition Numbers will be provided by the Organisers and must be affixed as specified below:

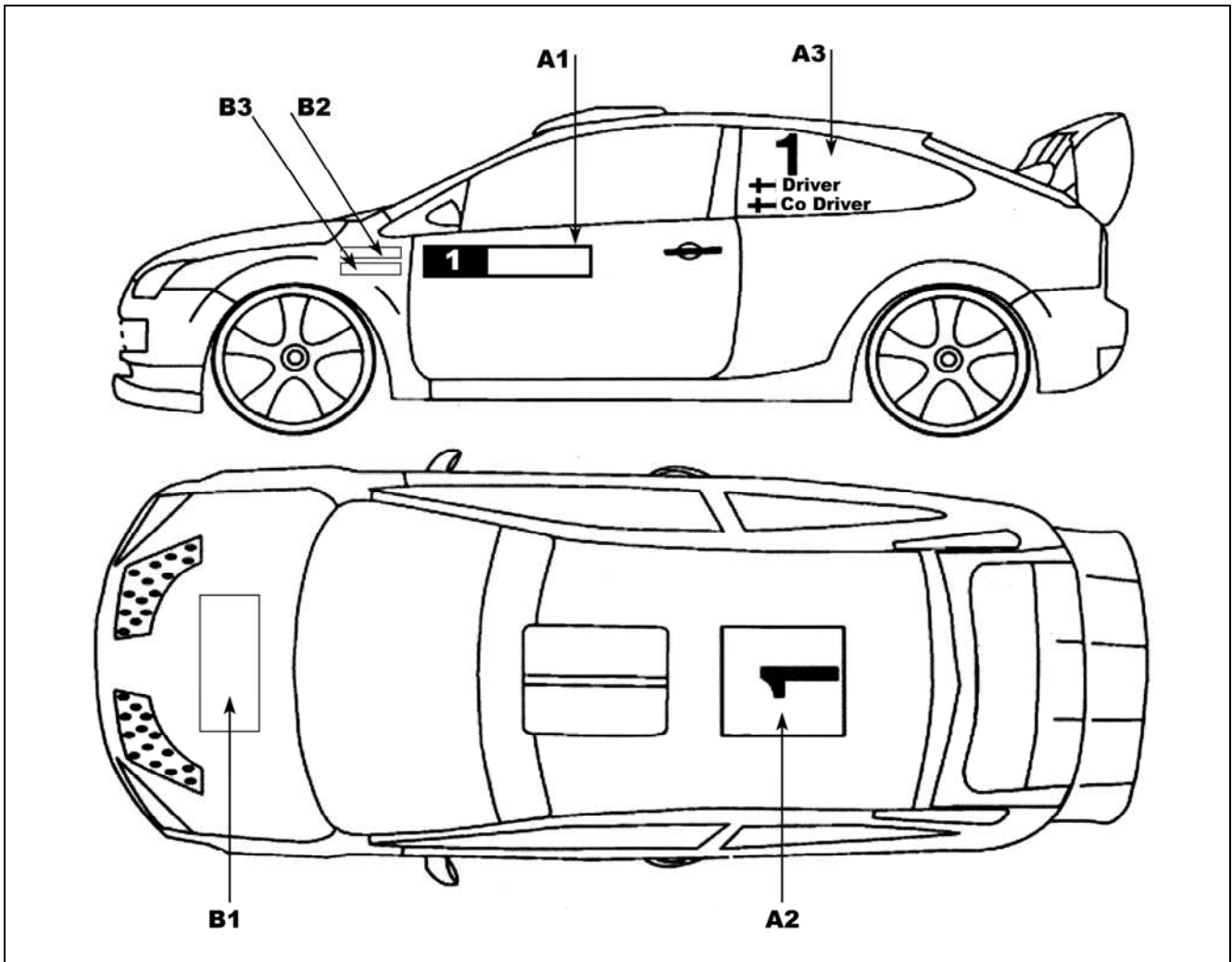

Competition Car Advertising

Competition Numbers

- A1: NAC Insurance / Hella 2 x front door panels 67cm long by 17cm high
- A2: NAC Insurance / Hella 1 x roof panel 50cm wide by 52cm high
- A3: 2 x numbers at the top of each rear side window 25cm high and Driver and Co-driver names, with their national flags, surname only in Helvetica upper case for the first letter, remainder in lower case, height 10cm and stroke width 1.5cm

Optional Advertising - refer FIA APCR Art 2.7

B1: Bonnet Size 10cm x 60cm

B2: 15cm x 25cm - Whangarei

B3: 15cm x 25cm – NAC Insurance

NZ Rally Championship Competitors – refer Portfolio.

Racetech[®]

www.racetechseats.com

hans

- New for 2008
- Value priced

Our Tether Systems Allow Unrestricted Vision

plus
VISION ADVANTAGE



alpinestars

- Alpinestars Apparel



- High Performance Brake Pads.



- Extinguisher Systems

TERRATRIP

- Tripmeters
- Intercoms
- Map Lights

monit



For more information refer to our Web site

Ph +64 (04) 939 0552 | Fax +64 (04) 939 0553 | Mob +64 (021) 939 053

Email sales@racetech.co.nz

alpinestars.com



Travis Pastrana



GP Tech suit

